

Rosemount™ 3051 Pressure Transmitter

with 4-20 mA HART® Revision 5 and 7 Selectable Protocol



Safety messages

NOTICE

Read this manual before working with the product. For personal and system safety and for optimum product performance, ensure you thoroughly understand the contents before installing, using, or maintaining this product.

For technical assistance, contacts are listed below:

Customer Central (Technical support, quoting, and order-related questions.)

- United States: 1-800-999-9307 (7:00 am to 7:00 pm Central Time)
- Asia Pacific: 65 777 8211
- Europe/Middle East/Africa: 49 (8153) 9390

North American Response Center (Equipment service needs.): 1-800-654-7768 (24 hours - includes Canada)

Outside of these areas, contact your local Emerson representative.

⚠ WARNING

Explosions

Explosions could result in death or serious injury.

In an explosion-proof/flameproof installation, do not remove the transmitter covers when power is applied to the unit.

Installation of device in an explosive environment must be in accordance with appropriate local, national, and international standards, codes, and practices. Review the *Product Certifications* section of the Rosemount 3051 [Product Data Sheet](#) for any restrictions associated with a safe installation.

Before connecting a handheld communicator in an explosive atmosphere, ensure the instruments are installed in accordance with intrinsically safe or non-incendive field wiring practices.

Process leaks

Process leaks may cause harm or result in death.

Install and tighten process connectors before applying pressure.

Do not attempt to loosen or remove flange bolts while the transmitter is in service.

Electrical shock

Electrical shock can result in death or serious injury.

Avoid contact with the leads and terminals. High voltage that may be present on leads can cause electrical shock.

Replacement equipment

Replacement equipment or spare parts not approved by Emerson for use as spare parts could reduce the pressure retaining capabilities of the transmitter and may render the instrument dangerous.

Use only bolts supplied or sold by Emerson as spare parts.

Improper assembly

Improper assembly of manifolds to traditional flange can damage sensor module.

For safe assembly of manifold to traditional flange, bolts must break back plane of flange web (i.e., bolt hole) but must not contact sensor module housing.

Severe changes in the electrical loop may inhibit HART Communication or the ability to reach alarm values. Therefore, Rosemount absolutely cannot warrant or guarantee that the correct Failure alarm level (High or Low) can be read by the host system at the time of annunciation.

⚠ WARNING

Physical access

Unauthorized personnel may potentially cause significant damage to and/or misconfiguration of end users' equipment. This could be intentional or unintentional and needs to be protected against.

Physical security is an important part of any security program and fundamental to protecting your system. Restrict physical access by unauthorized personnel to protect end users' assets. This is true for all systems used within the facility.

⚠ CAUTION

Nuclear applications

The products described in this document are not designed for nuclear-qualified applications. Using non-nuclear qualified products in applications that require nuclear-qualified hardware or products may cause inaccurate readings.

For information on Rosemount nuclear-qualified products, contact your local Emerson Sales Representative.

Contents

Chapter 1	Introduction.....	7
	1.1 Using this manual.....	7
	1.2 Models covered.....	7
	1.3 Product recycling/disposal.....	8
Chapter 2	Configuration.....	9
	2.1 Overview.....	9
	2.2 Safety messages.....	9
	2.3 System readiness.....	10
	2.4 Configuration basics.....	11
	2.5 Setting the loop to manual.....	14
	2.6 Verify configuration.....	15
	2.7 Basic setup of the transmitter.....	16
	2.8 Configuring the LCD display.....	23
	2.9 Detailed transmitter setup.....	24
	2.10 Configuring transmitter diagnostics.....	31
	2.11 Performing transmitter tests.....	35
	2.12 Configuring burst mode.....	37
	2.13 Establishing multidrop communication.....	39
Chapter 3	Hardware installation.....	43
	3.1 Overview.....	43
	3.2 Safety messages.....	43
	3.3 Considerations.....	44
	3.4 Installation procedures.....	46
Chapter 4	Electrical installation.....	67
	4.1 Overview.....	67
	4.2 Safety messages.....	67
	4.3 LCD display.....	68
	4.4 Configuring transmitter security.....	69
	4.5 Set transmitter alarm.....	72
	4.6 Electrical considerations.....	73
Chapter 5	Operation and maintenance.....	81
	5.1 Overview.....	81
	5.2 Safety messages.....	81
	5.3 Recommended calibration tasks.....	82
	5.4 Calibration overview.....	83
	5.5 Trim the pressure signal.....	87

	5.6 Trim the analog output.....	89
	5.7 Switching HART [®] revision.....	94
Chapter 6	Troubleshooting.....	97
	6.1 Overview.....	97
	6.2 Safety messages.....	97
	6.3 Troubleshooting for 4-20 mA output.....	98
	6.4 Diagnostic messages.....	99
	6.5 Disassembly procedures.....	107
	6.6 Reassemble.....	109
	6.7 Service support.....	112
Chapter 7	Safety Instrumented Systems (SIS) requirements.....	113
	7.1 Identify Rosemount 3051 safety certification.....	113
	7.2 Installation in SIS applications.....	113
	7.3 Configuring in SIS applications.....	114
	7.4 SIS operation and maintenance.....	115
	7.5 Inspection.....	117
Appendix A	Reference data.....	119
	A.1 Ordering information, specifications, and drawings.....	119
	A.2 Product certifications.....	119
Appendix B	Field Communicator menu trees and fast keys.....	121
	B.1 Field Communicator menu trees.....	121
	B.2 Field Communicator Fast Keys.....	125
Appendix C	Local Operator Interface (LOI).....	127
	C.1 LOI menu tree.....	127
	C.2 LOI menu tree - extended menu.....	128
	C.3 Enter numbers in the LOI.....	129
	C.4 Enter text in the LOI.....	130

1 Introduction

1.1 Using this manual

The sections in this manual provide information on installing, operating, and maintaining the Rosemount 3051 Pressure Transmitter. The sections are organized as follows:

[Configuration](#) provides instruction on commissioning and operating the transmitters. It also includes information on software functions, configuration parameters, and online variables.

[Hardware installation](#) contains mechanical installation instructions and field upgrade options.

[Electrical installation](#) contains electrical installation instructions and field upgrade options.

[Operation and maintenance](#) provides detailed information on calibrating and changing HART revisions.

[Troubleshooting](#) provides troubleshooting techniques for the most common operating problems.

[Safety Instrumented Systems \(SIS\) requirements](#) provides identification, installation, configuration, operation and maintenance, and inspection information for Safety Instrumented Systems.

[Reference data](#) provides information on how to access specifications, ordering information, and dimensional drawings.

[Field Communicator menu trees and fast keys](#) provides full menu trees and abbreviated Fast Key sequences for commissioning tasks.

[Local Operator Interface \(LOI\)](#) provides detailed LOI menu trees.

1.2 Models covered

The following Rosemount 3051 Transmitters are covered by this manual:

- Rosemount 3051C Coplanar™ Pressure Transmitter
 - Measures differential and gage pressure up to 2000 psi (137.9 bar).
 - Measures absolute pressure up to 4000 psia (275.8 bar).
- Rosemount 3051T In-Line Pressure Transmitter
 - Measures absolute pressure up to 20000 psi (1378.95 bar).
- Rosemount 3051L Liquid Level Transmitter
 - Measures level and specific gravity up to 300 psi (20.7 bar).
- Rosemount 3051CF Series Flowmeter
 - Measures flow in line sizes from ½-in. (15 mm) to 96-in. (2400 mm).

Note

For transmitter with FOUNDATION Fieldbus, see Rosemount 3051 [Reference Manual](#).

For transmitter with PROFIBUS® PA, see Rosemount 3051 [Reference Manual](#).

1.3 Product recycling/disposal

Consider recycling equipment. Dispose of packaging in accordance with local and national legislations/regulations.

2 Configuration

2.1 Overview

This section contains information on commissioning and tasks that should be performed on the bench prior to installation, as well as tasks performed after installation as described in [Configuring transmitter diagnostics](#).

This section also provides instructions on configuring with Field Communicator, AMS Device Manager, and Local Operator Interface (LOI). For convenience, Field Communicator Fast Key sequences are labeled *Fast Keys*, and abbreviated LOI menus are provided for each function below.

Full Field Communicator menu trees and Fast Key sequences are available in [Field Communicator menu trees and fast keys](#). LOI menu trees are available in [Local Operator Interface \(LOI\)](#).

2.2 Safety messages

Procedures and instructions in this section may require special precautions to ensure the safety of the personnel performing the operations.

⚠ WARNING

Explosions

Explosions could result in death or serious injury.

Before connecting a handheld communicator in an explosive atmosphere, ensure that the instruments in the loop are installed in accordance with intrinsically safe or non-incendive field wiring practices.

In an explosion-proof/flameproof installation, do not remove the transmitter covers when power is applied to the unit.

Process leaks

Process leaks may cause harm or result in death.

Install and tighten process connectors before applying pressure.

Electrical shock

Electrical shock can result in death or serious injury.

Avoid contact with the leads and terminals. High voltage that may be present on leads can cause electrical shock.

Static electricity

Observe safe handling precautions for static-sensitive components.

⚠ WARNING

Conduit/cable entries

Unless marked, the conduit/cable entries in the transmitter housing use a ½–14 NPT thread form. Entries marked “M20” are M20 × 1.5 thread form. On devices with multiple conduit entries, all entries will have the same thread form. Only use plugs, adapters, glands, or conduit with a compatible thread form when closing these entries.

When installing in a hazardous location, use only appropriately listed or Ex certified plugs, glands, or adapters in cable/conduit entries.

Replacement parts

Replacement equipment or spare parts not approved by Emerson for use as spare parts could reduce the pressure retaining capabilities of the transmitter and may render the instrument dangerous.

Use only bolts supplied or sold by Emerson as spare parts.

Improper assembly

Improper assembly of manifolds to traditional flange can damage sensor module.

For safe assembly of manifold to traditional flange, bolts must break back plane of flange web (i.e., bolt hole) but must not contact sensor module housing.

Severe changes in the electrical loop may inhibit HART® communication or the ability to reach alarm values. Therefore, Rosemount cannot absolutely warrant or guarantee that the correct Failure alarm level (High or Low) can be read by the host system at the time of annunciation.

Physical access

Unauthorized personnel may potentially cause significant damage to and/or misconfiguration of end users' equipment. This could be intentional or unintentional and needs to be protected against.

Physical security is an important part of any security program and fundamental to protecting your system. Restrict physical access by unauthorized personnel to protect end users' assets. This is true for all systems used within the facility.

2.3 System readiness

- If using HART®-based control or asset management systems, confirm the HART capability of such systems prior to commissioning and installation. Not all systems can communicate with HART Revision 7 devices.
- For instructions on how to change the HART revision of your transmitter, see [Switching HART® revision](#).

2.3.1 Confirm correct device driver

- Verify the latest Device Driver (DD/DTM™) is loaded on your systems to ensure proper communications.

- Download the latest DD at Emerson.com or FieldCommGroup.org
- In the **Browse by Member** dropdown menu, select Rosemount business unit of Emerson.
- Select desired product.
- Use the device revision numbers to find the correct Device Driver.

Table 2-1: Rosemount 3051 Device Revisions and Files

Release date	Device identification			Device driver identification		Review instructions	Review functionality
	NAMUR software revision ⁽¹⁾	HART hardware revision ⁽¹⁾	HART software revision ⁽²⁾	HART universal revision	Device revision ⁽³⁾	Manual document number	Change description
April 2012	1.0xx	1.0xx	01	7	10	00809-0100-4007	⁽⁴⁾
				5	9		
January 1998	N/A	N/A	178	5	3	00809-0100-4001	N/A

- (1) NAMUR Revision is located on the hardware tag of the device. Differences in level 3 changes, signified above by xx, represent minor product changes as defined per NES3. Compatibility and functionality are preserved, and you can use the product interchangeably.
- (2) You can read the HART software revision with a HART capable configuration tool. Value shown is minimum revision that could correspond to NAMUR Revisions.
- (3) Device Driver file names use Device and DD Revision, e.g., 10_01. HART Protocol is designed to enable legacy device driver revisions to continue to communicate with new HART devices. To access new functionality, you must download the new Device Driver. Emerson recommends downloading new Device Driver files to ensure full functionality.
- (4) HART Revision 5 and 7 selectable, power diagnostics, safety certified, LOI, process alerts, scaled variable, configurable alarms, expanded engineering units.

2.4 Configuration basics

⚠ CAUTION

Transmitter hardware adjustments

Set all transmitter hardware adjustments during commissioning to avoid exposing the transmitter electronics to the plant environment after installation.

You can configure the transmitter either before or after installation. To ensure all transmitter components are in working order prior to installation, configure the transmitter on the bench using a Field Communicator, AMS Device Manager, or LOI. Verify the **Security** switch is set in the Unlock position in order to proceed with configuration. See [Figure 4-2](#) for switch location.

2.4.1 Configuring on the bench

To configure on the bench, you need a power supply and a Field Communicator, AMS Device Manager, or LOI (option M4). Wire equipment as shown in [Figure 2-1](#) below. To ensure successful HART[®] Communication, verify the resistance between the transmitter

and the power supply is at least 250 Ω . See [Power supply for a 4-20 mA HART](#) for more details. Connect the Field Communicator to the terminals labeled **COMM** on the terminal block.

Figure 2-1: Wiring the Transmitter

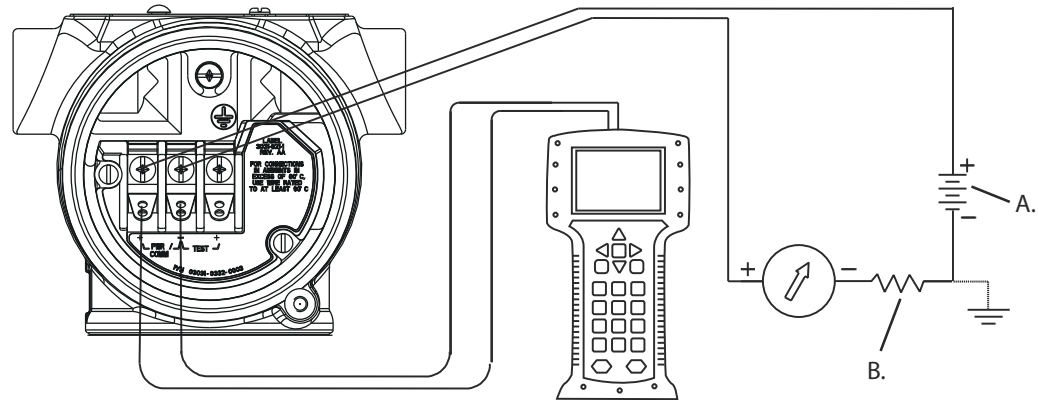

- A. Vdc supply
- B. $R_L \geq 250$ (necessary for HART Communication only)

2.4.2 Configuration tools

Configure with a Field Communicator

There are two interfaces available with the Field Communicator: Traditional and Dashboard. All steps using a Field Communicator are described using Dashboard interfaces.

[Figure 2-2](#) shows the Device Dashboard interface. As stated in [System readiness](#), it is critical that the latest DD's are loaded into the Field Communicator. Visit Emerson.com or FieldCommGroup.org to download latest DD library.

Field Communicator menu trees and Fast Keys are available in [Field Communicator menu trees and fast keys](#).

Figure 2-2: Device Dashboard

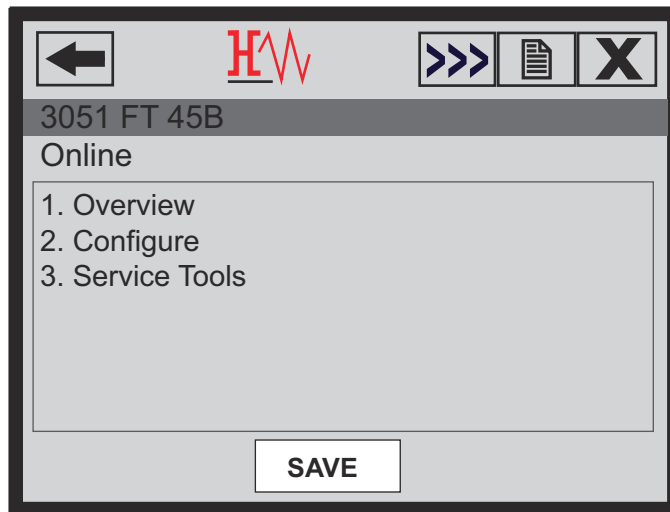

Configure with AMS Device Manager

Full configuration capability with AMS Device Manager requires loading the most current Device Descriptor (DD) for this device.

Download the latest DD at Emerson.com or FieldCommGroup.org.

Note

This manual describes all AMS Device Manager steps using version 11.5.

Configure with the LOI

To order the Rosemount 3051 Transmitter with the LOI, select option code M4 when ordering.

To activate the LOI, push either configuration button. Configuration buttons are located on the LCD display (must remove housing cover to access) or underneath the top tag of the transmitter. See [Table 2-2](#) for configuration button functionality and [Figure 2-3](#) for configuration button location. When using the LOI for configuration, several features require multiple screens for a successful configuration. Data entered is saved on a screen-by-screen basis; the LOI indicates this by flashing **SAVED** on the LCD display each time.

LOI menu trees are available in [Local Operator Interface \(LOI\)](#).

Figure 2-3: LOI Configuration Buttons

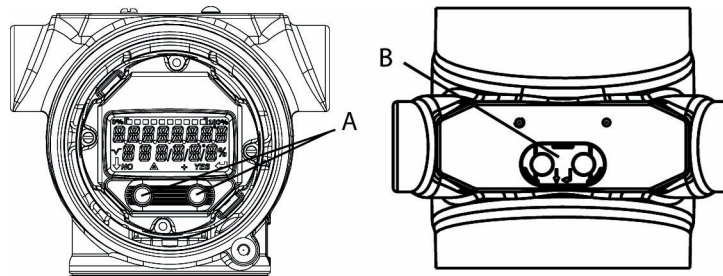

- A. Internal configuration buttons
- B. External configuration buttons

Table 2-2: LOI Button Operation

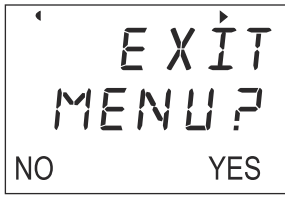
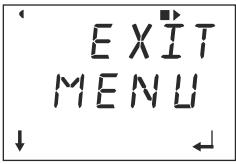
Button		
Left	No	Scroll
Right	Yes	Enter

2.5 Setting the loop to manual

Whenever sending or requesting data that would disrupt the loop or change the output of the transmitter, set the process application loop to manual control.

⚠ WARNING

Explosions

Explosions could result in death or serious injury.

Before connecting a handheld communicator in an explosive atmosphere, ensure the instruments are installed in accordance with intrinsically safe or non-incendive field wiring practices.

The Field Communicator, AMS Device Manager, or LOI will prompt you to set the loop to manual when necessary. The prompt is only a reminder; acknowledging this prompt does not set the loop to manual. You must set the loop to manual control as a separate operation.

2.6 Verify configuration

Emerson recommends that you verify various configuration parameters prior to installation into the process.

The following sections detail the various parameters for each configuration tool. Depending on what configuration tool(s) are available, follow the steps listed relevant to each tool.

2.6.1 Verify configuration with Field Communicator

Review configuration parameters listed in [Table 2-3](#) prior to transmitter installation. [Field Communicator menu trees and fast keys](#) provides a full list of configuration parameters that can be reviewed or configured using a Field Communicator.

[Table 2-3](#) shows Fast Key sequences for the latest DD. For Fast Key sequences for legacy DDs, contact your local Emerson representative.

From the **HOME** screen, enter the Fast Key sequences listed.

Table 2-3: Device Dashboard Fast Key Sequence

Function	Fast Key sequence	
	HART® 7	HART 5
Alarm and saturation levels	2, 2, 2, 5	2, 2, 2, 5
Damping	2, 2, 1, 1, 5	2, 2, 1, 1, 5
Primary variable	2, 1, 1, 4, 1	2, 1, 1, 4, 1
Range values	2, 1, 1, 4	2, 1, 1, 4
Tag	2, 2, 7, 1, 1	2, 2, 7, 1, 1
Transfer function	2, 2, 1, 1, 6	2, 2, 1, 1, 6
Units	2, 2, 1, 1, 4	2, 2, 1, 1, 4

2.6.2 Verify configuration with AMS Device Manager

Complete the following steps to verify the configuration parameters with the AMS Device Manager.

Procedure

1. Right-click the device and select Configuration Properties from the menu.
2. Navigate the tabs to review the transmitter configuration data.

2.6.3 Verify configuration with LOI

Complete the following steps to verify configuration parameters with the LOI.

Procedure

1. Press any configuration button to activate the LOI.

2. Select **VIEW CONFIG** to review the below parameters.
3. Use the configuration buttons to navigate through the menu.
The parameters you need to review prior to installation include:
 - Tag
 - Units
 - Transfer Function
 - Alarm and Saturation Levels
 - Primary Variable
 - Range Values
 - Damping

2.6.4 Verifying process variables configuration

This section describes how to verify that you selected the correct process variables.

Verify process variables with a Field Communicator

From the **HOME** screen, enter the Fast Key sequence:

Device Dashboard Fast Keys	3, 2, 1
----------------------------	---------

Verify process variables with AMS Device Manager

Complete the following steps to verify process variables with AMS Device Manager.

Procedure

1. Right-click the device and select Overview from the menu.
2. Select the **All Variables** button to display the primary, secondary, tertiary, and quaternary variables.

2.7 Basic setup of the transmitter

This section goes through the necessary steps for basic setup of a pressure transmitter.

When installing in DP level or DP flow applications, refer to [Configuring scaled variable](#) for setup instructions.

2.7.1 Setting pressure units

⚠ WARNING

Spare parts

Replacement equipment or spare parts not approved by Emerson for use as spare parts could reduce the pressure retaining capabilities of the transmitter and may render the instrument dangerous.

Use only bolts supplied or sold by Emerson as spare parts.

The pressure unit command sets the unit of measure for the reported pressure.

Set pressure units with a Field Communicator

From the *HOME* screen, enter the Fast Key sequence.

Device Dashboard Fast Keys	2, 2, 1, 1, 4
----------------------------	---------------

Set pressure units with AMS Device Manager

Complete the following steps to set pressure units with AMS Device Manager.

Procedure

1. Right-click the device and select **Configure**.
2. Select **Manual Setup** and select desired units from the *Pressure Units* dropdown menu.
3. Select **Send** when complete.

Set pressure units with the LOI

Complete the following steps to select pressure units with the LOI.

Procedure

1. Follow [Figure 2-4](#) to select desired pressure and temperature units. Go to **UNITS** → **PRESS UNITS**.

Figure 2-4: Selecting Pressure Units with LOI

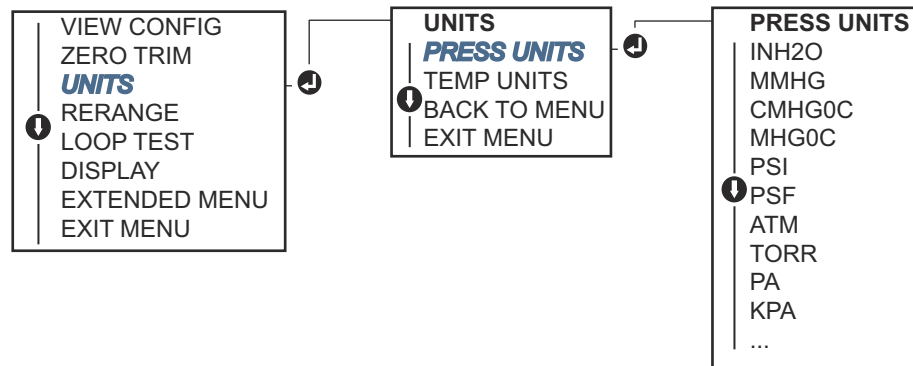

2. Use the **SCROLL** and **ENTER** buttons to select desired unit.
3. Save by selecting **SAVE** as indicated on the LCD display screen.

2.7.2 Setting transmitter output (transfer function)

The transmitter has two output settings: Linear and Square root.

As shown in [Figure 2-6](#), activating the square root options makes analog output proportional to flow and includes a fixed Low Flow Cutoff at five percent.

However, Emerson recommends using scaled variable for Differential Pressure (DP) Flow and DP Level applications. Refer to [Configuring scaled variable](#) for setup instructions.

Set transmitter output with a Field Communicator

From the **HOME** screen, enter the Fast Key sequence.

Device Dashboard Fast Keys	2, 2, 1, 1, 6
----------------------------	---------------

Set transmitter output with AMS Device Manager

Complete the following steps to set transmitter output with AMS Device Manager.

Procedure

1. Right-click the device and select **Configure**.
2. Select **Manual Setup**, select output type from **Analog Output Transfer Function**, and click **Send**.
3. Carefully read the warning and select **Yes** if it is safe to apply the changes.

Set transmitter output with the LOI

Reference [Figure 2-5](#) to select either linear or square root transfer function using the LOI. Go to **EXTENDED MENU** → **TRANSFER FUNCT**.

Figure 2-5: Set Transmitter Output with LOI

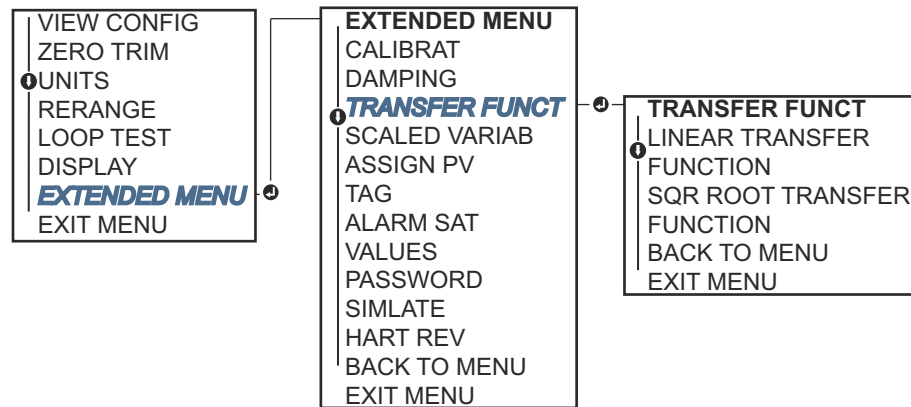
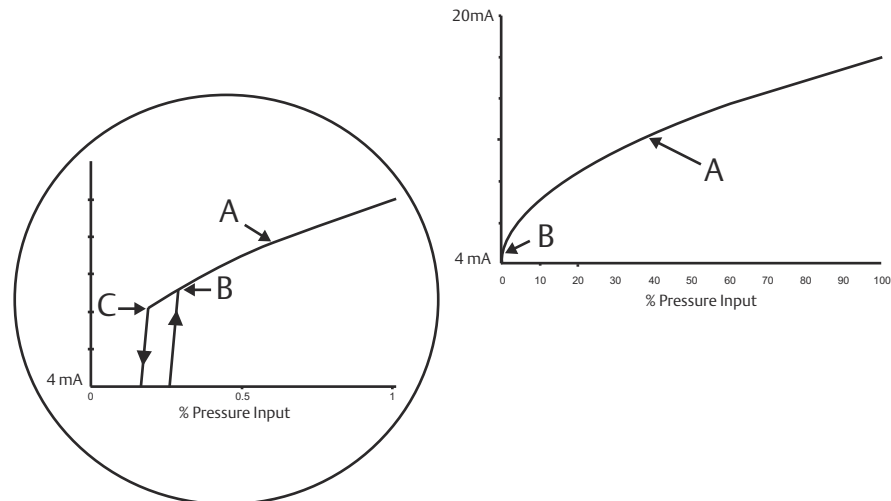

Figure 2-6: 4-20 mA HART® Square Root Output Transition Point



- A. Square root curve
- B. 5% transition point
- C. 4% transition point

2.7.3 Rerange the transmitter

The range values command sets each of the lower and upper range analog values (4 and 20 mA points) to a pressure. The lower range represents zero percent of range, and the upper range point represents 100 percent of range.

In practice, you can change the transmitter range values as often as necessary to reflect changing process requirements. For a complete listing of range and sensor limits, refer to the *Specifications* section of the Rosemount 3051 [Product Data Sheet](#).

Select from one of the methods below to rerange the transmitter. Each method is unique; examine all options closely before deciding which method works best for your process.

- Rerange by manually setting range points with a Field Communicator, AMS Device Manager, or LOI.
- Rerange with a pressure input source and a Field Communicator, AMS Device Manager, LOI, or local **Zero** and **Span** buttons.

Manually rerange the transmitter by entering range points

Enter range points with a Field Communicator

From the **HOME** screen, enter the Fast Key sequence.

Device Dashboard Fast Keys	2, 2, 2, 1
----------------------------	------------

Enter range points with AMS Device Manager

Complete the following steps to manually enter range points with AMS Device Manager.

Procedure

1. Right-click the device and select **Configure**.
2. Select **Manual Setup** and select **Analog Output**.
3. Enter upper and lower range values in the **Range Limits** box and select **Send**.
4. Carefully read the warning and select **Yes** if it is safe to apply the changes.

Enter range points with LOI

Reference [Figure 2-7](#) to rerange the transmitter using the LOI. Go to **RERANGE** → **ENTER VALUES**. Enter values using the **SCROLL** and **ENTER** buttons.

Figure 2-7: Rerange with LOI

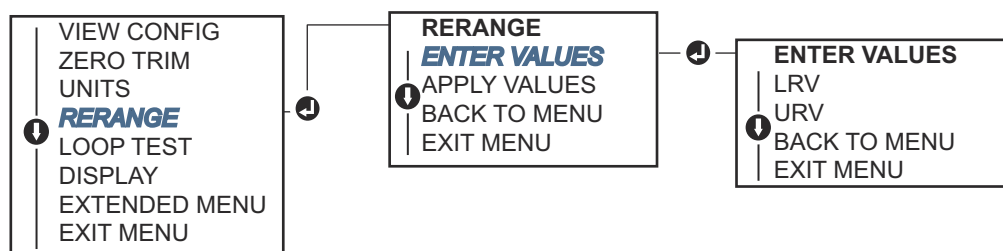

Rerange the transmitter with applied pressure source

Reranging using an applied pressure source is a way of reranging the transmitter without entering specific 4 and 20 mA points.

Rerange with an applied pressure source using a Field Communicator

From the **HOME** screen, enter the Fast Key sequence.

Device Dashboard Fast Keys	2, 2, 2, 2
----------------------------	------------

Rerange with an applied pressure source using AMS Device Manager

Complete the following steps to use an applied pressure source to rerange the transmitter with AMS Device Manager.

Procedure

1. Right-click the device; select **Configure**.
2. Select the **Analog Output** tab.
3. Select **Range by Applying Pressure** button and follow the screen prompts to range the transmitter.

Rerange with an applied pressure source using the LOI

Use [Figure 2-8](#) to manually rerange the device using an applied pressure source with the LOI. Go to **RERANGE** → **APPLY VALUES**.

Figure 2-8: Rerange with Applied Pressure Using LOI

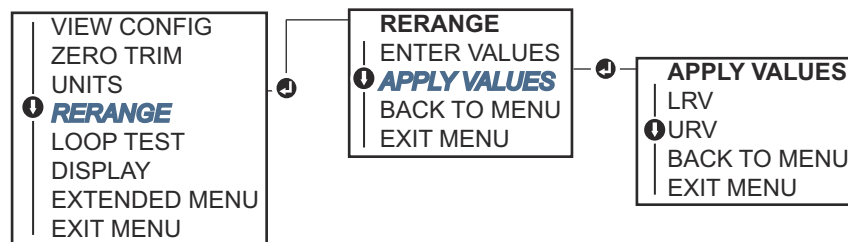

Rerange with an applied pressure source using local Zero and Span buttons

If you order them to, you can use local **Zero** and **Span** buttons (option code D4) to rerange the transmitter with applied pressure.

Refer to [Figure 2-9](#) for analog **Zero** and **Span** button location.

Figure 2-9: Analog Zero and Span Buttons

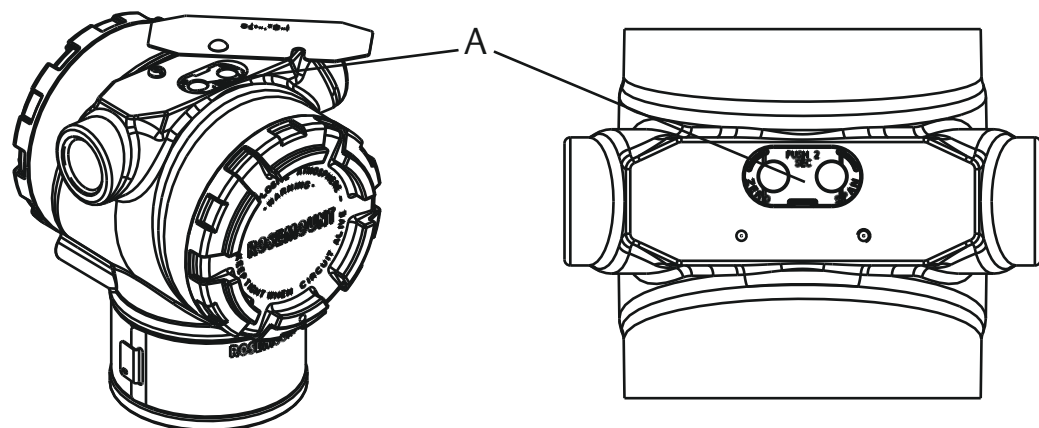

A. *Zero and Span buttons*

To rerange the transmitter using the **Zero** and **Span** buttons:

Procedure

1. Loosen the screw holding the top tag of the transmitter housing. Rotate the label to expose the **Zero** and **Span** buttons.
2. Confirm device has local **Zero** and **Span** buttons by verifying blue retainer under the tag.
3. Apply transmitter pressure.
4. Rerange the transmitter.
 - a) To change the zero (4 mA point) while maintaining the span, press and hold the **Zero** button for at least two seconds; then release.
 - b) To change the span (20 mA) point while maintaining the zero point, press and hold the **Span** button for at least two seconds and then release.

Note

4 and 20 mA points must maintain the minimum span defined in the *Specifications* section of the Rosemount 3051 [Product Data Sheet](#).

- If the transmitter security is on, you cannot adjust the zero and span. Refer to [Configuring transmitter security](#) for security information.
- The span is maintained when you set the 4 mA point. The span changes when you set the 20 mA point. If you set the lower range point to a value that causes the upper range point to exceed the sensor limit, the transmitter automatically sets the upper range point to the sensor limit and adjusts the span accordingly.
- Regardless of the range points, the Rosemount 3051 measures and reports all readings within the digital limits of the sensor. For example, if you set the 4 and 20 mA points to 0 and 10 inH₂O, and the transmitter detects a pressure of 25 inH₂O, it digitally outputs the 25 inH₂O reading and a 250 percent of range reading.

2.7.4 Damping

The damping command changes the response time of the transmitter; higher values can smooth variations in output readings caused by rapid input changes.

⚠ CAUTION

Improper assembly

Improper assembly of manifolds to traditional flange can damage sensor module.

For safe assembly of manifold to traditional flange, bolts must break back plane of flange web (i.e., bolt hole) but must not contact sensor module housing.

Severe changes in the electrical loop may inhibit HART® communication or the ability to reach alarm values. Therefore, Rosemount cannot absolutely warrant or guarantee that the correct Failure alarm level (High or Low) can be read by the host system at the time of annunciation.

Determine the appropriate damping setting based on the necessary response time, signal stability, and other requirements of the loop dynamics within your system. The damping command uses floating point configuration, allowing you to input any damping value within 0 - 60 seconds.

Damping with a Field Communicator

1. From the *HOME* screen, enter the Fast Key sequence.

Device Dashboard Fast Keys	2, 2, 1, 1, 5
----------------------------	---------------

2. Enter desired damping value and select **APPLY**.

Damping with AMS Device Manager

Complete the following steps to set the damping value with AMS Device Manager.

Procedure

1. Right-click the device, and select **Configure**.
2. Select **Manual Setup**.
3. Within the *Pressure Setup* box, enter desired damping value and click **Send**.
4. Carefully click the warning and click **Yes** if it is safe to apply the changes.

Damping with the LOI

Reference [Figure 2-10](#) to enter damping values using the LOI. Go to **EXTENDED MENU** → **DAMPING**.

Figure 2-10: Damping with LOI

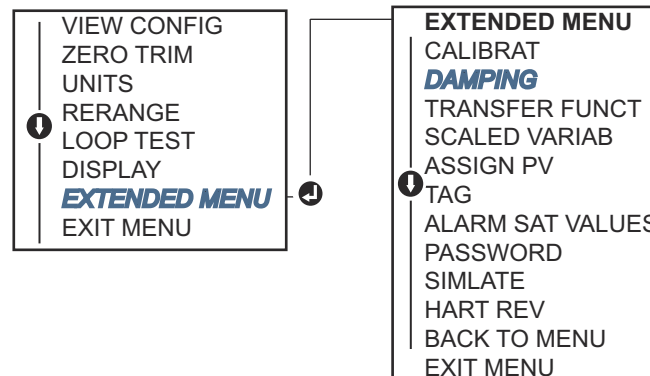

2.8 Configuring the LCD display

Use the LCD display configuration command to customize of the LCD display to suit application requirements. The LCD display will alternate between the selected items.

- Pressure units

- % of range
- Scaled variable
- Sensor temperature
- mA output

Using the following instructions, you can configure the LCD display to display configuration information during the device setup. Select Review Parameters at Startup to enable or disable this functionality.

2.8.1 Configure LCD display with a Field Communicator

From the **HOME** screen, enter the Fast Key sequence.

Device Dashboard Fast Keys	2, 2, 4
----------------------------	---------

2.8.2 Configure LCD display with AMS Device Manager

Complete the following steps to configure the LCD display with AMS Device Manager.

Procedure

1. Right-click the device and select **Configure**.
2. Click **Manual Setup** and select the **Display** tab.
3. Select desired display options and select **Send**.

2.8.3 Configure LCD display with the LOI

Refer to [Figure 2-11](#) for LCD display configuration using the LOI. Go to **DISPLAY**.

Figure 2-11: Display with LOI

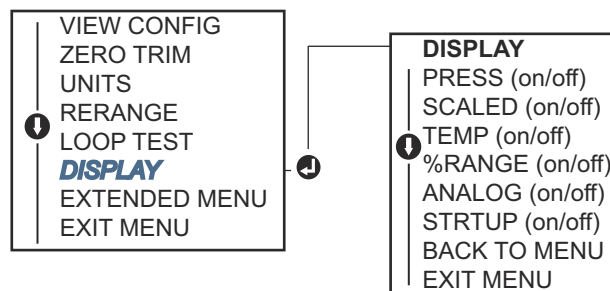

2.9 Detailed transmitter setup

2.9.1 Configuring alarm and saturation levels

In normal operation, the transmitter drives the output in response to pressure from the lower and upper saturation points. If the pressure goes outside of the sensor limits, or if

the output would be beyond the saturation points, the output will be limited to the associated saturation point.

The Rosemount 3051 Transmitter automatically and continuously performs self-diagnostic routines. If the self-diagnostic routines detect a failure, the transmitter drives the output to configured alarm and value based on the position of the alarm switch. See [Set transmitter alarm](#).

Table 2-4: Rosemount Alarm and Saturation Values

Level	4-20 mA saturation	4-20 mA alarm
Low	3.9 mA	≤ 3.75 mA
High	20.8 mA	≥ 21.75 mA

Table 2-5: NAMUR-Compliant Alarm and Saturation Values

Level	4-20 mA saturation	4-20 mA alarm
Low	3.8 mA	≤ 3.6 mA
High	20.5 mA	≥ 22.5 mA

Table 2-6: Custom Alarm and Saturation Values

Level	4-20 mA saturation	4-20 mA alarm
Low	3.7 - 3.9 mA	3.6 - 3.8 mA
High	20.1 - 22.9 mA	20.2 - 23.0 mA

You can configure failure mode alarm and saturation levels using a Field Communicator, AMS Device Manager, or the LOI. The following limitations exist for custom levels:

- Low alarm level must be less than the low saturation level.
- High alarm level must be higher than the high saturation level.
- Alarm and saturation levels must be separated by at least 0.1 mA.

The configuration tool provides an error message if the configuration rule is violated.

Note

Transmitters set to HART® multidrop mode send all saturation and alarm information digitally; saturation and alarm conditions will not affect the analog output. See also [Establishing multidrop communication](#).

Configure alarm and saturation levels using a Field Communicator

From the **HOME** screen, enter the Fast Key sequence.

Device Dashboard Fast Keys	2, 2, 2, 5, 6
----------------------------	---------------

Configure alarm and saturation levels with AMS Device Manager

Complete the following steps to configure alarm and saturation levels with AMS Device Manager.

Procedure

1. Right-click the device and select **Configure**.
2. Select the **Configure Alarm and Saturation Levels** button.
3. Follow screen prompts to configure alarm and saturation levels.

Configure alarm and saturation levels using the LOI

Refer to [Figure 2-12](#) for instructions to configure alarm and saturation levels. Go to **EXTENDED MENU** → **ALARM SAT VALUES**.

Figure 2-12: Configuring Alarm and Saturation with LOI

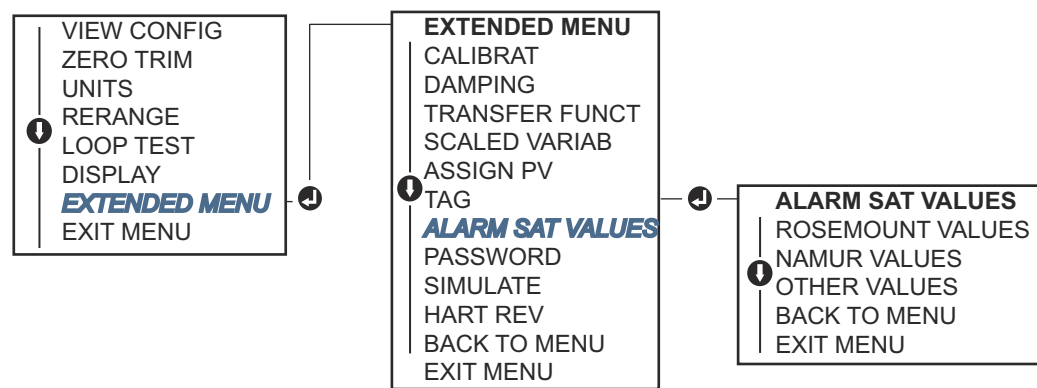

2.9.2 Configuring process alerts

The transmitter uses process alerts to indicate when it exceeds the configured data point. You can set process alerts for pressure, temperature, or both. An alert is displayed on a Field Communicator or AMS Device Manager status screen or in the error section of the LOI/LCD display. The alert will reset once the value returns within range.

Note

HI alert value must be higher than LO alert value. Both alert values must be within the pressure or temperature sensor limits.

Configure process alerts using a Field Communicator

Complete the following steps to configure process alerts with a Field Communicator.

Procedure

1. From the **HOME** screen, enter the Fast Key sequence.

Device Dashboard Fast Keys	2, 3
----------------------------	------

2. Select either **Pressure Alert** or **Temperature Alert** and press **ENTER**.
3. Select **Configure Alert**.
4. Follow screen prompts to configure process alerts.

Configure process alerts using AMS Device Manager

Complete the following steps to configure process alerts with AMS Device Manager.

Procedure

1. Right-click the device and select **Configure**.
2. Select **Guided Setup**.
3. Select the **Process Alerts** button.
4. Follow screen prompts to configure process alerts.

2.9.3 Configuring scaled variable

With the scaled variable configuration, you can create a relationship/conversion between the pressure units and user-defined/custom units. There are two use cases for a scaled variable. The first is to allow custom units to be displayed on the transmitter's LOI/LCD display. The second is to allow custom units to drive the transmitter's 4-20 mA output.

If you desire custom units to drive the 4-20 mA output, you must remap scaled variable as the primary variable. Refer to [Re-mapping device variables](#).

The scaled variable configuration defines the following items:

- Scaled variable units: Custom units to be displayed.
- Scaled data options: Defines the transfer function for the application.
 - Linear
 - Square root
- Pressure value position 1: Lower known value point with consideration of linear offset.
- Scaled variable value position 1: Custom unit equivalent to the lower known value point.
- Pressure value position 2: Upper known value point.
- Scaled variable value position 2: Custom unit equivalent to the upper known value point.
- Linear offset: The value required to zero out pressures effecting the desired pressure reading.
- Low flow cutoff: Point at which output is driven to zero to prevent problems cause by process noise. Emerson highly recommends using the low flow cut off function in order to have a stable output and avoid problems due to process noise at a low flow or no flow condition. Enter a low flow cutoff value that is practical for the flow element in the application.

Configure scaled variable using a Field Communicator

Complete the following steps to configure a scaled variable with a Field Communicator.

Procedure

1. From the **HOME** screen, enter the Fast Key sequence.

Device Dashboard Fast Keys	2, 1, 5, 7
----------------------------	------------

2. Follow the screen prompts to configure scaled variable.
 - When configuring for level, select Linear under **Select Scaled data** options.
 - When configuring for flow, select Square Root under **Select Scaled data** options.

Configure scaled variable using AMS Device Manager

Complete the following steps to configure the scaled variable with AMS Device Manager.

Procedure

1. Right-click the device and select **Configure**.
2. Select the **Scaled Variable** tab and select the **Scaled Variable** button.
3. Follow screen prompts to configure the scaled variable.
 - When configuring for level applications, select **Linear** under **Select Scaled data** options.
 - When configuring the flow applications, select **Square Root** under **Select Scaled data** options.

Configure scaled variable using the LOI

Refer to [Figure 2-13](#) for instructions on configuring scaled variable using the LOI. Go to **EXTENDED MENU** → **SCALED VARIAB** → **CONFIG SCALED**.

Figure 2-13: Configuring Scaled Variable Using the LOI

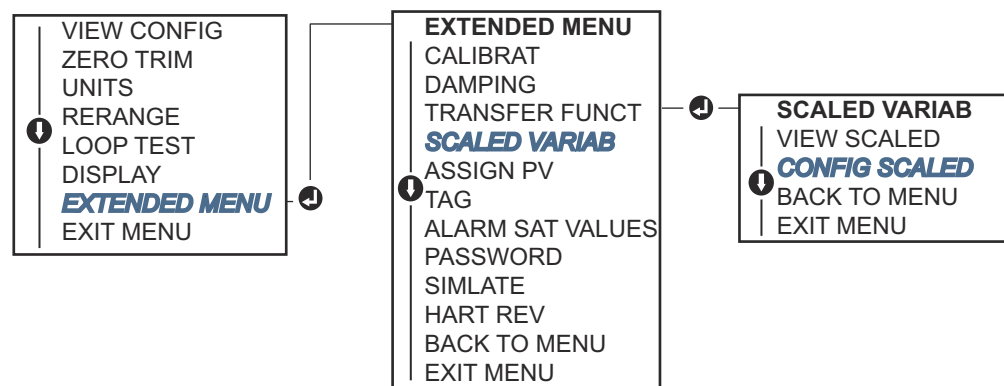

DP Level example

Figure 2-14: Example Tank

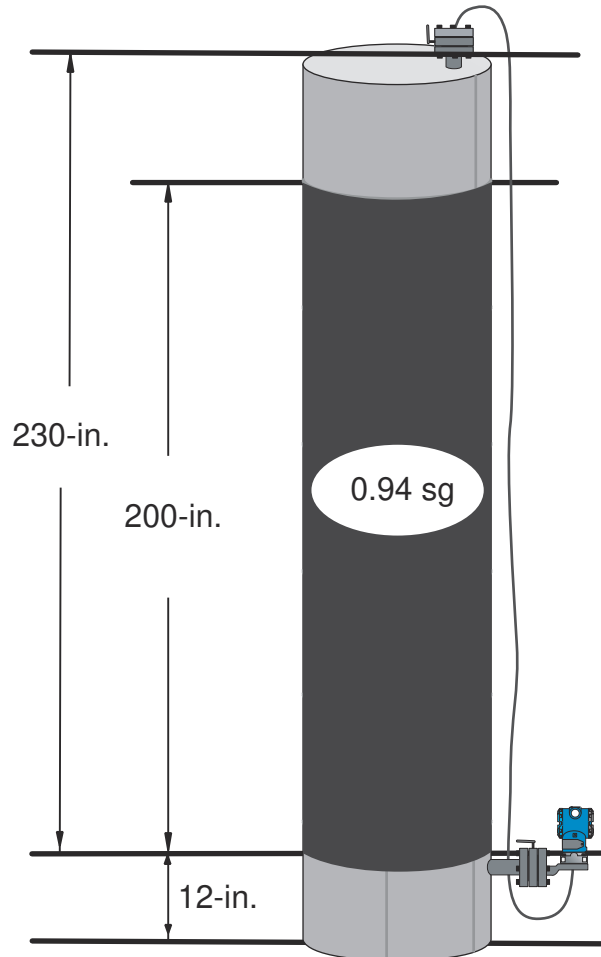

Use a differential transmitter in a level application. Once installed on an empty tank with the taps vented, the process variable reading is $-209.4 \text{ inH}_2\text{O}$. The process variable reading is the head pressure created by fill fluid in the capillary. Based on [Table 2-7](#), the scaled variable configuration would be as follows:

Table 2-7: Scaled Variable Configuration for Tank Application

Scaled variable units	inch
Scaled data options	linear
Pressure value position 1	$0 \text{ inH}_2\text{O}$
Scaled variable position 1	12-in.
Pressure value position 2	$188 \text{ inH}_2\text{O}$

Table 2-7: Scaled Variable Configuration for Tank Application (continued)

Scaled variable position 2	212-in.
Linear offset	-209.4 inH ₂ O

DP Flow example

Use a differential pressure transmitter in conjunction with an orifice plate in a flow application where the differential pressure at full scale flow is 125 inH₂O.

Emerson highly recommends using the low flow cutoff function in order to have a stable output and avoid problems due to process noise at a low flow or no flow condition. Enter a low flow cutoff value that is practical for the flow element in the application. In this particular example, the low flow cutoff value is 1000 gallons of water per hour. Based on this information, the scaled variable configuration would be as follows:

Table 2-8: Scaled Variable Configuration for Flow Application

Scaled variable units	gal/h
Scaled data options	square root
Pressure value position 2	125 inH ₂ O
Scaled variable position 2	20,000 gal/h
Low flow cutoff	1000 gal/h

Note

Pressure value position 1 and scaled variable position 1 are always set to zero for a flow application. You don't have to configure these values.

2.9.4 Re-mapping device variables

Use the re-mapping function to configure the transmitter primary, secondary, tertiary, and quaternary variables (PV, 2V, 3V, and 4V). You can map the PV with a Field Communicator, AMS Device Manager, or the LOI. You can only re-map variables (2V, 3V, and 4V) via Field Communicator or AMS Device Manager.

Note

The variable assigned to the primary variable drives the 4-20 mA output. You can select this value as Pressure or Scaled Variable. The 2, 3, and 4 variables only apply if you are using HART® burst mode.

Re-map using a Field Communicator

From the **HOME** screen, enter the Fast Key sequence.

Fast Keys	2, 1, 1, 3
-----------	------------

Re-map using AMS Device Manager

Complete the following steps to re-map device variables using AMS Device Manager.

Procedure

1. Right-click the device and select **Configure**. Select **Manual Setup** and click the **HART** tab.
2. Under **Variable Mapping**, assign primary, secondary, tertiary, and quaternary variables .
3. Carefully read the warning and select **Yes** if it is safe to apply the changes.

Re-map using LOI

Refer to [Figure 2-15](#) for instructions to remap the primary variable using the LOI. Go to **EXTENDED MENU** → **ASSIGN PV**.

Figure 2-15: Re-Mapping with LOI

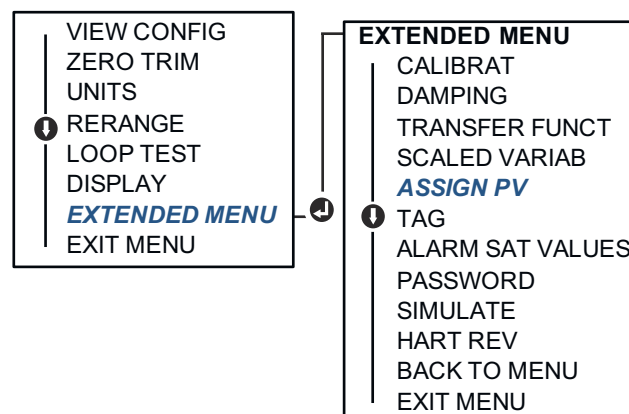

2.10 Configuring transmitter diagnostics

The diagnostics and service functions listed below are primarily for use after field installation.

2.10.1 Configuring power advisory diagnostic

You can use the optional power advisory diagnostic (option code DA0) to detect issues that may jeopardize the integrity of the electrical loop. Some examples are: water entering the wiring compartment and making contact with the terminals, an unstable power supply nearing end of life, or heavy corrosion on the terminals.

The technology is based on the premise that once a transmitter is installed and powered up, the electrical loop has a baseline characteristic that reflects the proper installation. If the transmitter terminal voltage deviates from the baseline and outside the user configured threshold, the transmitter can generate a HART® alert or analog alarm.

To use the diagnostic, you must first create a baseline characteristic for the electrical loop after installing the transmitter. The loop is automatically characterized with the push of a

button. This creates a linear relationship for expected terminal voltage values along the operating region from 4-20 mA. See [Figure 2-16](#).

Figure 2-16: Baseline Operating Region

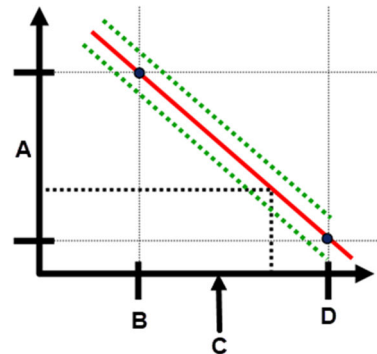

- A. Terminal voltage
- B. 4 mA
- C. Output current
- D. 20 mA

Overview

Emerson ships transmitters ordered with power advisory diagnostic (option code DA0) with power advisory off as default and without any loop characterization performed. Once you have installed and powered up the transmitter, you must perform loop characterization for Power Advisory diagnostic to function.

When you initiate a loop characterization, the transmitter checks to see if the loop has sufficient power for proper operation. Then the transmitter drives the analog output to both 4 and 20 mA to establish a baseline and determine the maximum allowable terminal voltage deviation. Once this is complete, you enter a sensitivity threshold called Terminal Voltage Deviation Limit, and a check is in place to ensure this threshold value is valid.

Once you have characterized the loop and set the terminal voltage deviation limit, power advisory actively monitors the electrical loop for deviations from the baseline. If the terminal voltage has changed relative to the expected baseline value, exceeding the configured terminal voltage deviation limit, the transmitter can generate an alert or alarm.

Note

Power advisory diagnostic in the Rosemount 3051 HART® Pressure Transmitter monitors and detects changes in the terminal voltage from expected values to detect common failures. It is not possible to predict and detect all types of electrical failures on the 4-20 mA output. Therefore, Rosemount cannot absolutely warrant or guarantee that the power advisory diagnostic will accurately detect failures under all circumstances.

Terminal voltage

This field shows the current terminal voltage value in volts. the terminal voltage is a dynamic value and is directly related to the mA output value.

Terminal voltage deviation limit

Set the terminal voltage deviation limit large enough that *expected* voltage changes do not cause false failures.

Figure 2-17: Voltage Deviation Limit

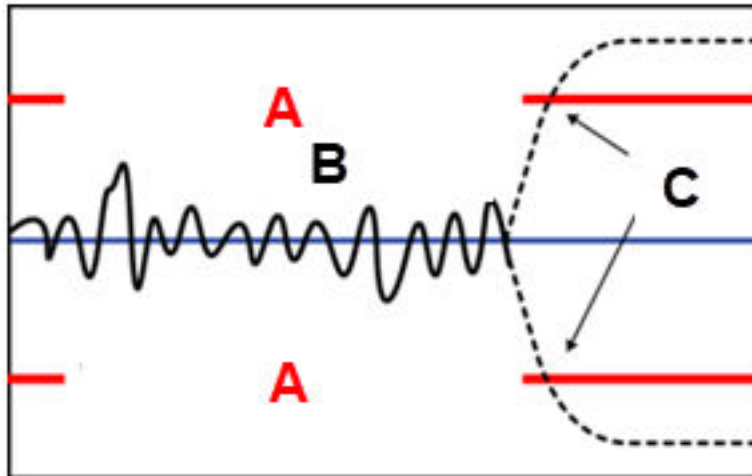

- A. Voltage deviation limit
- B. Terminal voltage
- C. Alert

⚠ CAUTION

Changes in electrical loop

Severe changes in the electrical loop may inhibit HART[®] communication or the ability to reach alarm values. Therefore, Rosemount cannot absolutely warrant or guarantee that the correct Failure alarm level (High or Low) can be read by the host system at the time of annunciation.

For safe assembly of manifold to traditional flange, bolts must break back plane of flange web (i.e., bolt hole) but must not contact sensor module housing.

Resistance

This value is the calculated resistance of the electrical loop (in Ω s) measured during the characterize loop procedure. Changes in the resistance may occur due to changes in the physical condition of the loop installation. You can compare baseline and previous baselines to see how much resistance has changed over time.

Power supply

This value is the calculated power supply voltage of the electrical loop (in volts) measured during the characterize loop procedure. Changes in this value may occur due to degraded performance of the power supply. You can compare baseline and previous baselines to see how much the power supply has changed over time.

Characterize loop

You must initiate loop characterization when you have first installed the transmitter or when you have intentionally altered electrical loop characteristics. Examples include modified power supply level or loop resistance of the system, changing the terminal block on the transmitter, or adding the Wireless THUM™ Adapter to the transmitter.

Note

Emerson does not recommend power advisory diagnostic for transmitters operating in multidrop mode.

Power advisory action

When the voltage deviation exceeds the set limit, you can configure four possible actions and set them to Latched or Unlatched.

When the alert or alarm is Unlatched, the alert or alarm will disappear if voltage deviation returns to a normal level. A Latched alarm or alert will not disappear when the voltage deviation returns to normal levels. You have to acknowledge and clear the alert or alarm.

The four power advisory diagnostic actions are:

- None
- Alert latched
- Alarm unlatched
- Alert unlatched

Configure power advisory diagnostic with a Field Communicator

From the **HOME** screen, enter the Fast Key sequence.

Device Dashboard Fast Keys	2, 1, 7, 2, 3
----------------------------	---------------

Configure power advisory diagnostic using AMS Device Manager

Complete the following steps to configure the optional power advisory diagnostic with AMS Device Manager.

Procedure

1. Right-click the device and select **Configure**.
2. Select **Guided Setup**.
3. Select the **Power Advisory** button.
4. Follow screen prompts to configure power advisory diagnostic.

2.11 Performing transmitter tests

2.11.1 Verifying alarm level

If the transmitter electronics board, sensor module, or LOI/ LCD display is repaired or replaced, verify the transmitter alarm level before returning the transmitter to service. This is useful in testing the reaction of the control system to a transmitter in an alarm state, thus ensuring the control system recognizes the alarm when activated.

To verify the transmitter alarm values, perform a loop test and set the transmitter output to the alarm value (see [Table 2-4](#) and [Table 2-6](#)).

Note

Before returning transmitter to service, verify security switch is set to the correct configuration. Refer to [Verify configuration](#).

2.11.2 Performing an analog loop test

The analog loop test command verifies the output of the transmitter, the integrity of the loop, and the operations of any recorders or similar devices installed in the loop. Emerson recommends that you verify the 4-20 mA points in addition to alarm levels when installing, repairing, or replacing a transmitter.

⚠ CAUTION

Improper assembly

Improper assembly of manifolds to traditional flange can damage sensor module.

Severe changes in the electrical loop may inhibit HART® communication or the ability to reach alarm values. Therefore, Rosemount cannot absolutely warrant or guarantee that the correct Failure alarm level (High or Low) can be read by the host system at the time of annunciation.

The host system may provide a current measurement for the 4–20 mA HART output. If it does not, connect a reference meter to the transmitter by either connecting the meter to the test terminals on the terminal block or shunting transmitter power through the meter at some point in the loop.

Perform an analog loop test using a Field Communicator

From the *HOME* screen, enter the Fast Key sequence.

Device Dashboard Fast Keys	3, 5, 1
----------------------------	---------

Perform an analog loop test using AMS Device Manager

Complete the following steps to perform an analog loop test, which verifies the output of the transmitter, with AMS Device Manager.

Procedure

1. Right-click the device and, within the **Methods** drop down menu, move cursor over Diagnostics and Test. In the **Diagnostics and Test** drop-down menu select Loop Test.
2. Set the control loop to manual and select **Next**.
3. Follow screen prompts to perform a loop test.
4. Select **Finish** to acknowledge the method is complete.

Perform analog loop test using LOI

To perform an analog loop test using the LOI, set the 4 mA, 20 mA, and custom mA point manually.

Reference [Figure 2-18](#) for instructions on how to perform a transmitter loop test using the LOI. Go to **LOOP TEST**.

Figure 2-18: Performing an Analog Loop Test Using the LOI

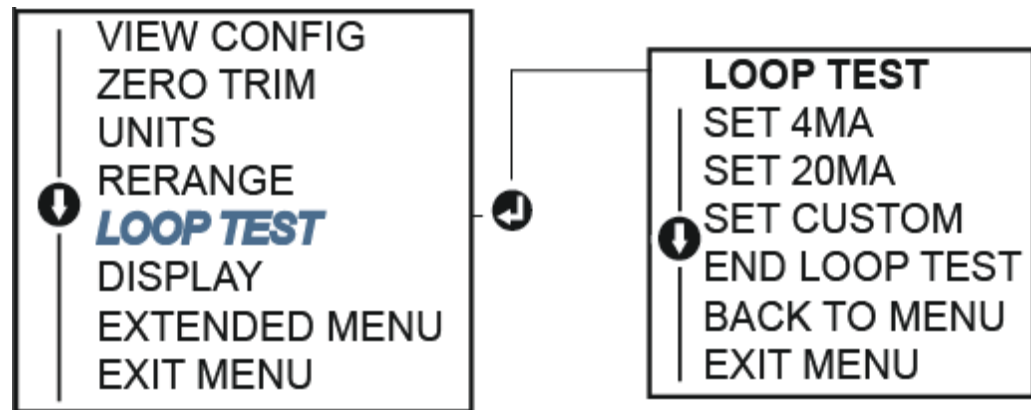

2.11.3 Simulating device variables

You can temporarily set the pressure, sensor temperature, or scaled variable to a user-defined fixed value for testing purposes.

Once the simulated variable method is left, the transmitter automatically returns the process variable to a live measurement. You can only simulate device variables in HART® Revision 7 mode.

Simulate digital signal with a Field Communicator

From the **HOME** screen, enter the Fast Key sequence.

Device Dashboard Fast Keys	3, 5
----------------------------	------

Simulate digital signal with AMS Device Manager

Complete the following steps to simulate a digital value with AMS Device Manager.

Procedure

1. Right-click the device and select Service Tools.
2. Select **Simulate**.
3. Under **Device Variables**, select a digital value to simulate.
The options are:
 - Pressure
 - Sensor Temperature
 - Scaled Variable
4. Follow the screen prompts to simulate the selected digital value.

2.12 Configuring burst mode

Burst mode is compatible with the analog signal. Because the HART[®] protocol features simultaneous digital and analog data transmission, the analog value can drive other equipment in the loop while the control system is receiving digital information.

Burst mode applies only to the transmission of dynamic data (pressure and temperature in engineering units, pressure in percent of range, scaled variable, and/or analog output) and does not affect the way other transmitter data is accessed. However, when activated, burst mode can slow down communication of non-dynamic data to the host by 50 percent.

The transmitter accesses information other than dynamic transmitter data through the normal poll/response method of HART Communication. A Field Communicator, AMS Device Manager, or the control system may request any of the information that is normally available while the transmitter is in burst mode. Between each message sent by the transmitter, a short pause allows the Field Communicator, AMS Device Manager, or a control system to initiate a request.

2.12.1 Selecting burst mode options in HART[®] 5

The message content options are:

- PV only
- Percent of range
- PV, 2V, 3V, 4V
- Process variables
- Device status

2.12.2 Selecting burst mode options in HART® 7

The message content options are:

- PV only
- Percent of range
- PV, 2V, 3V, 4V
- Process variables and status
- Process variables
- Device status

2.12.3 Selecting a HART® 7 trigger mode

When in HART 7 mode, you can select the following trigger modes

- Continuous (same as HART 5 burst mode)
- Rising
- Falling
- Windowed
- On change

Note

Consult host system manufacturer for burst mode requirements.

2.12.4 Configure burst mode using a Field Communicator

From the **HOME** screen, enter the Fast Key sequence.

Device Dashboard Fast Keys	2, 2, 5, 3
----------------------------	------------

2.12.5 Configure burst mode using AMS Device Manager

Complete the following steps to configure burst mode, in order to transmit dynamic data, with AMS Device Manager.

Procedure

1. Right-click the device and select **Configure**.
2. Select the **HART** tab.
3. Enter the configuration in the **Burst Mode Configuration** fields.

2.13 Establishing multidrop communication

Multidrop communication refers to the connection of several transmitters to a single communications transmission line. Communication between the host and the transmitters takes place digitally with the analog output of the transmitters deactivated.

To install multidrop communication, you must consider the update rate necessary from each transmitter, the combination of transmitter models, and the length of the transmission line. You can communicate with transmitters with HART® modems and a host implementing HART protocol. Each transmitter is identified by a unique address and responds to the commands defined in the HART protocol. Field Communicators and AMS Device Manager can test, configure, and format a multidropped transmitter the same way as a transmitter in a standard point-to-point installation.

Figure 2-19 shows a typical multidrop network. This figure is not intended as an installation diagram.

Note

A multidrop transmitter in HART Revision 7 mode has a fixed analog output of 4 mA for all but one device. Only one device is allowed to have an active analog signal.

Figure 2-19: Typical Multidrop Network

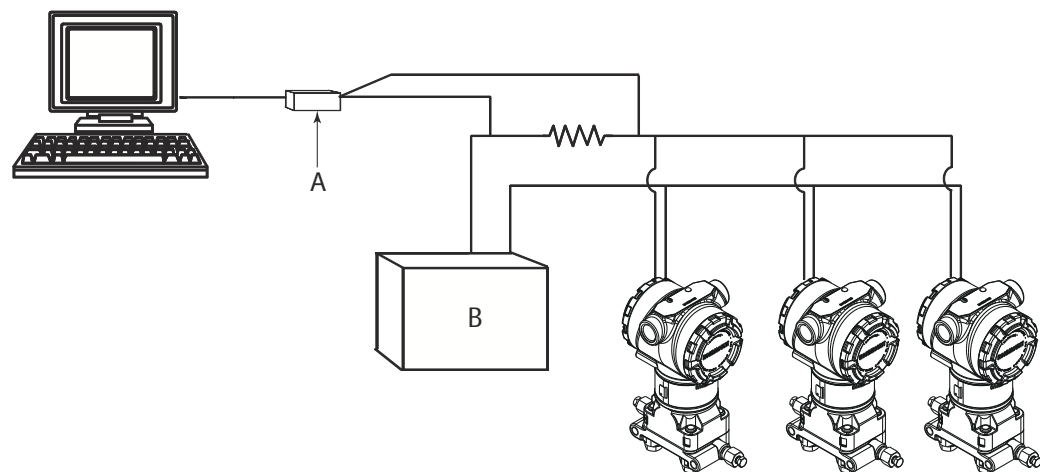

- A. HART modem
- B. Power supply

Emerson sets the Rosemount 3051 to address zero (0) at the factory, which allows operation in the standard point-to-point manner with a 4-20 mA output signal. To activate multidrop communication, you must change the transmitter address to a number from 1 to 15 for HART Revision 5 or 1 to 63 for HART Revision 7. This change deactivates the 4-20 mA analog output, sending it to 4 mA. It also disables the failure mode alarm signal, which is controlled by the upscale/downscale switch position. HART messages communicate failure signals in multidropped transmitters.

2.13.1 Changing a transmitter address

To activate multidrop communication, you must assign the transmitter poll address to a number from 1 to 15 for HART® Revision 5 and 1 to 63 for HART Revision 7.

Each transmitter in a multidropped loop must have a unique poll address.

Change transmitter address using Field Communicator

From the **HOME** screen, enter the Fast Key sequence.

	HART® Revision 5	HART Revision 7
Device Dashboard Fast Keys	2, 2, 5, 2, 1	2, 2, 5, 2, 2,

Change transmitter address using AMS Device Manager

Complete the following steps to change the transmitter address, in order to activate multidrop communication, using AMS Device Manager.

Procedure

1. Right-click the device and select **Configure**.
2. Change the polling address.
 - In HART® Revision 5 mode:
 - a. Click **Manual Setup** and select the **HART** tab.
 - b. In the **Communication Settings** box, enter the polling address in the Polling Address field and click **Send**.
 - In HART Revision 7 mode, click **Manual Setup**, select the **HART** tab, and click the **Change Polling Address** button.

2.13.2 Communicating with a multidropped transmitter

To communicate with a multidropped transmitter, set up the Field Communicator or AMS Device Manager for polling.

Communicate with a multidrop transmitter using a Field Communicator

Complete the following steps to set up a Field Communicator for polling.

Procedure

1. Select **Utility** and **Configure HART Application**.
2. Select **Polling Addresses**.
3. Enter **0-63**.

Communicate with a multidropped transmitter using AMS Device Manager

1. Click the **HART** modem icon.
2. select **Scan All Devices**.

3 Hardware installation

3.1 Overview

The information in this section covers installation considerations for the Rosemount 3051 with HART® protocols. Emerson ships a [Quick Start Guide](#) with every transmitter to describe recommended pipe-fitting and wiring procedures for each initial installation.

Dimensional drawings for each Rosemount 3051 variation and mounting configuration are included in [Mounting brackets](#).

Note

For transmitter disassembly and reassembly, refer to [Disassembly procedures](#) and [Reassemble](#).

3.2 Safety messages

Procedures and instructions in this section may require special precautions to ensure the safety of personnel performing the operation.

⚠ WARNING

Explosions

Explosions could result in death or serious injury.

Installation of device in an explosive environment must be in accordance with appropriate local, national, and international standards, codes, and practices.

Before connecting a handheld communicator in an explosive atmosphere, ensure that the instruments in the loop are installed in accordance with intrinsically safe or non-incendive field wiring practices.

In an explosion-proof/flameproof installation, do not remove the transmitter covers when power is applied to the unit.

Process leaks

Process leaks may cause harm or result in death.

Install and tighten process connectors before applying pressure.

Install and tighten all four flange bolts before applying pressure.

Do not attempt to loosen or remove flange bolts while the transmitter is in service.

Electrical shock

Electrical shock can result in death or serious injury.

Avoid contact with the leads and terminals. High voltage that may be present on leads can cause electrical shock.

⚠ WARNING

Spare parts

Replacement equipment or spare parts not approved by Emerson for use as spare parts could reduce the pressure retaining capabilities of the transmitter and may render the instrument dangerous.

Use only bolts supplied or sold by Emerson as spare parts.

⚠ CAUTION

Improper assembly

Improper assembly of manifolds to traditional flange can damage sensor module.

For safe assembly of manifold to traditional flange, bolts must break back plane of flange web (i.e., bolt hole) but must not contact sensor module housing.

3.3 Considerations

3.3.1 Installation considerations

Measurement accuracy depends upon proper installation of the transmitter and impulse piping. Mount the transmitter close to the process and use a minimum of piping to achieve best accuracy. Keep in mind the need for easy access, personnel safety, practical field calibration, and a suitable transmitter environment. Install the transmitter to minimize vibration, shock, and temperature fluctuation.

Important

Install the enclosed pipe plug (found in the box) in unused housing conduit opening with a minimum of five threads of engagement to comply with explosion-proof requirements. For material compatibility considerations, refer to Material Selection [Technical Note](#).

3.3.2 Environmental considerations

The best practice is to mount the transmitter in an environment that has minimal ambient temperature change.

The transmitter electronics operating temperature limits are -40 to 185 °F (-40 to 85 °C). Refer to the Specifications section in the Rosemount 3051 [Product Data Sheet](#) to view the sensing element operating limits. Mount the transmitter so it is not susceptible to vibration and mechanical shock and does not have external contact with corrosive materials.

3.3.3 Mechanical considerations

Steam service

For steam service or for applications with process temperatures greater than the limits of the transmitter, do not blow down impulse piping through the transmitter. Flush lines

with the blocking valves closed and refill lines with water before resuming measurement. Refer to [Figure 3-9](#) for correct mounting orientation.

Side mounted

When the transmitter is mounted on its side, position the coplanar flange to ensure proper venting or draining. Mount the flange as shown in [Figure 3-9](#), keeping drain/vent connections on the bottom for gas service and on the top for liquid service.

3.3.4 Draft range considerations

Installation

For the Rosemount 3051CD0 draft range pressure transmitter, it is best to mount the transmitter with the isolators parallel to the ground.

See [Figure 3-1](#) for a draft range installation example on a Rosemount 304 manifold. Installing the transmitter in this way reduces oil head effect.

Tilting of the transmitter may cause a zero shift in the transmitter output, but you can eliminate this by performing a trim procedure.

Figure 3-1: Draft Range Installation Example

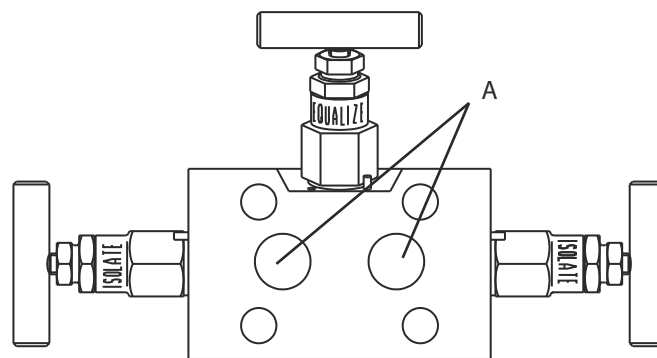

A. Isolators

Reducing process noise

Rosemount 3051CD0 draft transmitters are sensitive to small pressure changes. Increasing the damping will decrease output noise, but will further reduce response time. In gage applications, it is important to minimize pressure fluctuations to the low side isolator.

Output damping

At the factory, Emerson sets the output damping for the Rosemount 3051CD0 to 3.2. If the transmitter output is still noisy, increase the damping time. If you need a faster response, decrease the damping time. See [Damping](#) for damping adjustment information.

Reference side filtering

In gage applications, it is important to minimize fluctuations in atmospheric pressure to which the low side isolator is exposed.

One method of reducing fluctuations in atmospheric pressure is to attach a length of tubing to the reference side of the transmitter to act as a pressure buffer.

3.4 Installation procedures

3.4.1 Mount the transmitter

For dimensional drawing information refer to the *Dimensional Drawings* section of the Rosemount 3051 [Product Data Sheet](#).

Process flange orientation

Mount the process flanges with sufficient clearance for process connections. For safety reasons, place the drain/vent valves so the process fluid is directed away from possible human contact when the vents are used. In addition, consider the need for a testing or calibration input.

Rotate housing

You can rotate the electronics housing up to 180 degrees in either direction to improve field access or to better view the optional LCD/LOI display. To rotate the housing:

Figure 3-2: Transmitter Housing Set Screw

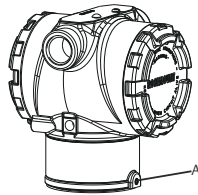

A. Housing rotation set screw (5/64-in.)

Procedure

1. Loosen the housing rotation set screw using a 5/64-in. hex wrench.

CAUTION

Transmitter damage

Over rotating can damage the transmitter.

Do not rotate the transmitter more than 180°.

2. Turn the housing left or right up to 180° from its original position.⁽¹⁾
3. Re-tighten the housing rotation set screw.

(1) Rosemount 3051C original position aligns with "H" side; Rosemount 3051T original position is the opposite side of bracket holes.

Electronics housing clearance

Mount the transmitter so the terminal side is accessible.

To remove the cover, ensure there is clearance of 0.75-in. (19 mm). Use a conduit plug in the unused conduit opening. You need three inches of clearance to remove the cover if a meter is installed.

Environmental seal for housing

For NEMA® 4X, IP66, and IP68 requirements, use thread sealing (PTFE) tape or paste on male threads of conduit to provide a water and dust tight seal.

Always ensure a proper seal by installing the electronics housing cover(s) so that metal contacts metal. Use Rosemount O-rings.

Flange bolts

Emerson can ship the Rosemount 3051 with a coplanar flange or a traditional flange installed with four 1.75-in. flange bolts.

See [Table 3-1](#) and [Figure 3-3](#) for mounting bolts and bolting configurations for the coplanar and traditional flanges. Emerson supplies stainless steel bolts coated with a lubricant to ease installation. Carbon steel bolts do not require lubrication. Do not apply additional lubrication when installing either type of bolt. Bolts supplied by Emerson are identified by their head markings.

Bolt installation

Use the following bolt installation procedure:

⚠ WARNING

Spare parts

Replacement equipment or spare parts not approved by Emerson for use as spare parts could reduce the pressure retaining capabilities of the transmitter and may render the instrument dangerous.

Use only bolts supplied or sold by Emerson as spare parts.

Table 3-1: Bolt Installation Torque Values

Bolt material	Initial torque value	Final torque value
CS-(ASTM-A445) standard	300 in-lb (34 N-m)	650 in-lb (73 N-m)
Austemitic 316 SST—Option L4	150 in-lb (17 N-m)	300 in-lb (34 N-m)
ASTM A193 Grade B7M—Option L5	300 in-lb (34 N-m)	650 in-lb (73 N-m)

Figure 3-3: Traditional Flange Bolt Configurations

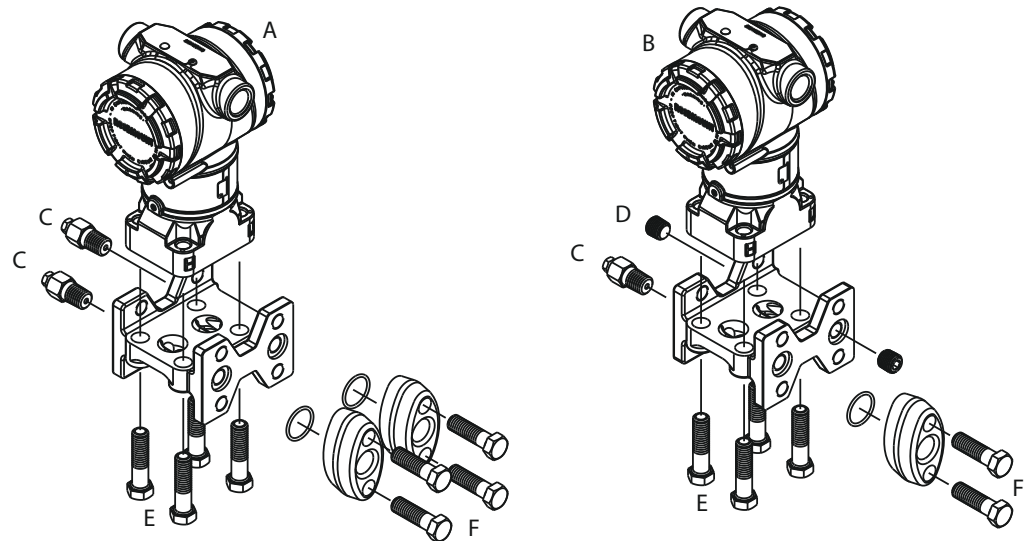

- A. Differential transmitter
- B. Gage/absolute transmitter
- C. Drain/vent
- D. Vented fitting
- E. 1.75 (44) x 4
- F. 1.50 (38) x 4⁽²⁾

Dimensions are in inches (millimeters).

⁽²⁾ For gage and absolute transmitters: 150 (38) x 2

Figure 3-4: Mounting Bolts and Bolt Configurations for Coplanar Flange

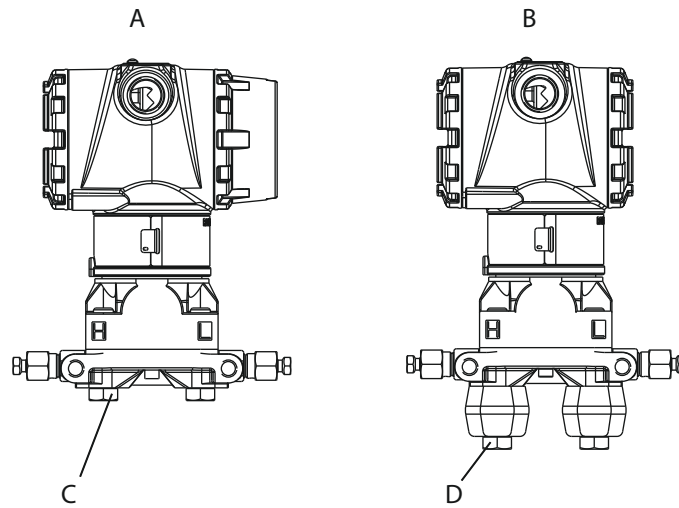

- A. Transmitter with flange bolts
- B. Transmitter with flange adapters and flange/adaptor bolts
- C. 1.75 (44) x 4
- D. 2.88 (73) x 4

Dimensions are in inches (millimeters).

Description	Qty	Size in. (mm)
Differential pressure		
Flange bolts	4	1.75 (44)
Flange/adapter	4	2.88 (73)
Gage/absolute pressure ⁽¹⁾		
Flange bolts	4	1.75 (44)
Flange/adapter bolts	2	2.88 (73)

(1) Rosemount 3051T Transmitters are direct mount and do not require bolts for process connection.

Figure 3-5: Mounting Bracket Option Codes B1, B7, and BA

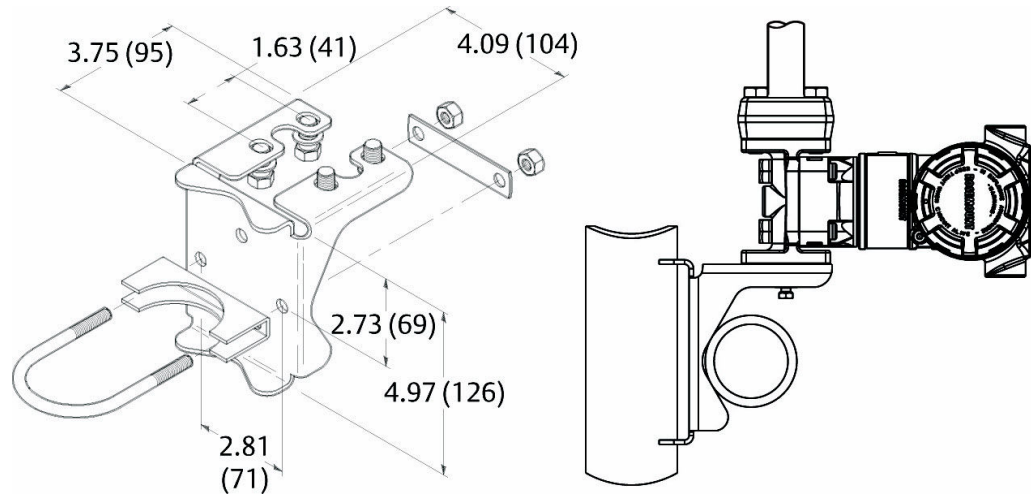

Dimensions are in inches (millimeters).

Figure 3-6: Panel Mounting Bracket Option Codes B2 and B8

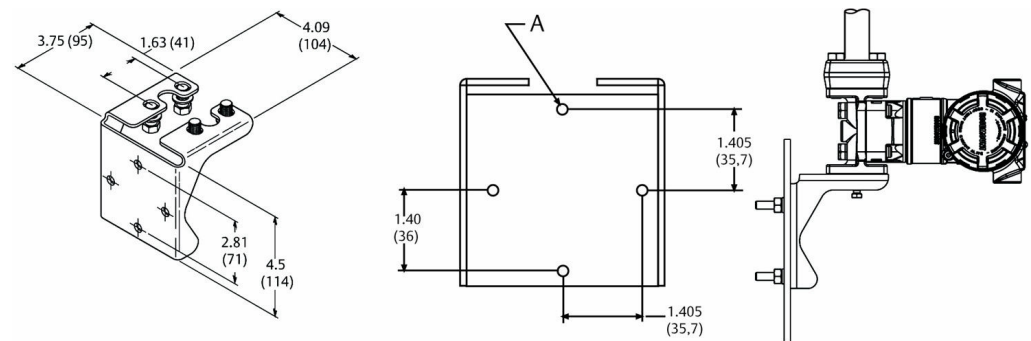

A. Mounting holes 0.375 diameter (10)

Dimensions are in inches (millimeters).

Figure 3-7: Flat Mounting Bracket Option Codes B3 and BC

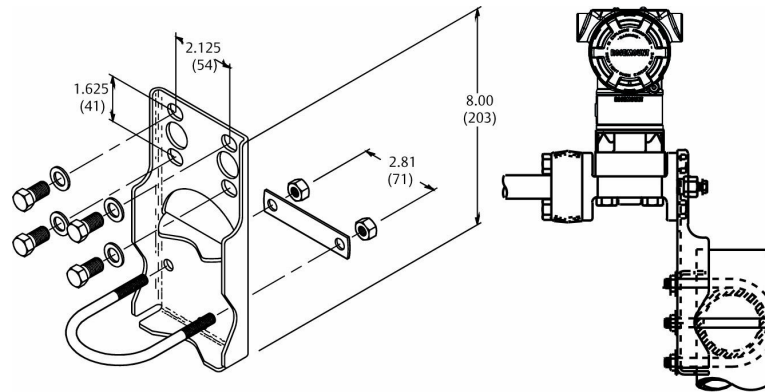

Dimensions are in inches (millimeters).

1. Use the fingers to tighten the bolts.
2. Torque the bolts to the initial torque value using a crossing pattern (see [Table 3-1](#) for torque values).
3. Torque the bolts to the final torque value using the same crossing pattern.

Mounting brackets

You can use an optional mounting bracket to panel mount or pipe mount the Rosemount 3051 Transmitter.

Refer to [Table 3-2](#) for the complete offering and see [Figure 3-7](#) and [Figure 3-8](#) for dimensional and mounting configuration information.

Table 3-2: Mounting Brackets

Option code	Process connections			Mounting			Materials			
	Coplanar	In-Line	Traditional	Pipe mount	Panel mount	Flat panel mount	CS bracket	SST bracket	CS bolts	SST bolts
B4	X	X	N/A	X	X	X	N/A	X	N/A	X
B1	N/A	N/A	X	X	N/A	N/A	X	N/A	X	N/A
B2	N/A	N/A	X	N/A	X	N/A	X	N/A	X	N/A
B3	N/A	N/A	X	N/A	N/A	X	X	N/A	X	N/A
B7	N/A	N/A	X	X	N/A	N/A	X	N/A	N/A	X
B8	N/A	N/A	X	N/A	X	N/A	X	N/A	N/A	X
B9	N/A	N/A	X	N/A	N/A	X	X	N/A	N/A	X
BA	N/A	N/A	X	X	N/A	N/A	N/A	X	N/A	X
BC	N/A	N/A	X	N/A	N/A	X	N/A	X	N/A	X

Figure 3-8: Mounting Bracket Option Code B4

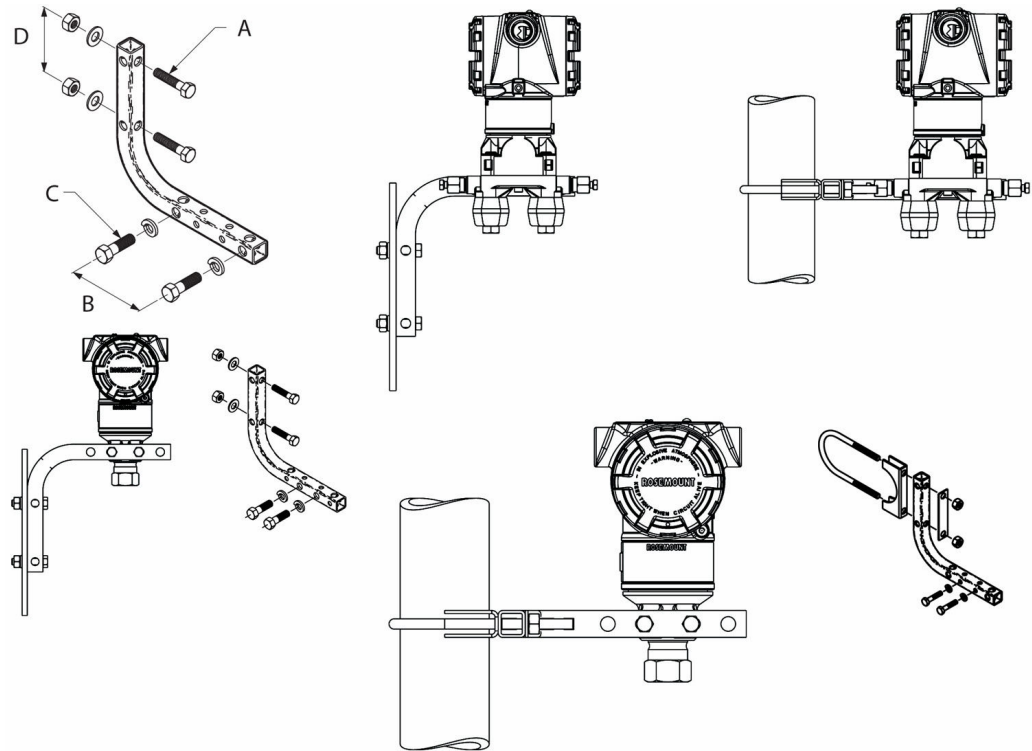

- A. $5/16 \times 1\frac{1}{2}$ bolts for panel mounting (not supplied)
- B. 3.4 (85)
- C. $\frac{3}{8}$ -16 $\times 1\frac{1}{4}$ bolts for mounting to transmitter
- D. 2.8 (71)

Dimensions are in inches (millimeters).



Carbon steel (CS) head markings



Stainless steel (SST) head markings



Alloy K-500 head marking

1. The last digit in the F593_ head marking may be any letter between A and M.

3.4.2 Impulse piping

Mounting requirements

Impulse piping configurations depend on specific measurement conditions. Refer to [Figure 3-9](#) for examples of the following mounting configurations:

Liquid measurement

- Place taps to the side of the line to prevent sediment deposits on the transmitter's process isolators.
- Mount the transmitter beside or below the taps so gases can vent into the process line.
- Mount drain/vent valve upward to allow gases to vent.

Gas measurement

- Place taps in the top or side of the line.
- Mount the transmitter beside or above the taps so liquid will drain into the process line.

Steam measurement

- Place taps to the side of the line.
- Mount the transmitter below the taps to ensure that the impulse piping will stay filled with condensate.
- In steam service above 250 °F (121 °C), fill impulse lines with water to prevent steam from contacting the transmitter directly and to ensure accurate measurement start-up.

Note

For steam or other elevated temperature services, it is important that temperatures at the process connection do not exceed the transmitter's process temperature limits.

Figure 3-9: Installation Examples

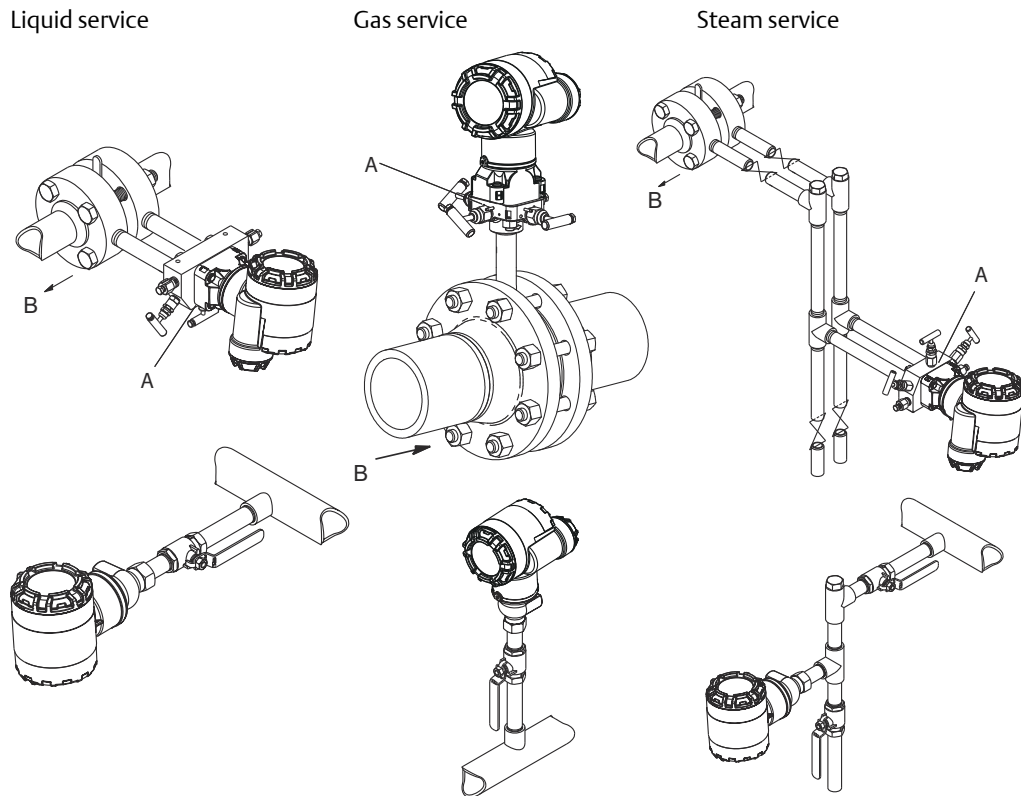

- A. Drain/vent valves
- B. Flow

Best practices

The piping between the process and the transmitter must accurately transfer the pressure to obtain accurate measurements. There are five possible sources of error: pressure transfer, leaks, friction loss (particularly if purging is used), trapped gas in a liquid line, liquid in a gas line, and density variations between the legs.

The best location for the transmitter in relation to the process pipe is dependent on the process. Use the following guidelines to determine transmitter location and placement of impulse piping.

- Keep impulse piping as short as possible.
- For liquid service, slope the impulse piping at least 1 in./ft. (8 cm/m) upward from the transmitter toward the process connection.
- For gas service, slope the piping at least 1 in./ft. (8 cm/m) downward from the transmitter toward the process connection.
- Avoid high points in liquid lines and low points in gas lines.
- Ensure impulse legs are the same temperature.

- Use impulse piping large enough to avoid friction effects and blockage.
- Vent all gas from liquid piping legs.
- When using a sealing fluid, fill both piping legs to the same level.
- When purging, make the purge connection close to the process taps and purge through equal lengths of the same size pipe. Avoid purging through the transmitter.
- Keep corrosive or hot (above 250 °F [121 °C]) process material out of direct contact with the sensor modules and flanges.
- Prevent sediment deposits in the impulse piping.
- Maintain equal leg of head pressure on both legs of the impulse piping.
- Avoid conditions that might allow process fluids to freeze within the process flange.

3.4.3 Process connections

Coplanar or traditional process connection

⚠ WARNING

Process leaks

Process leaks could result in death or serious injury.

- Install and tighten all four flange bolts before applying pressure.
- Do not attempt to loosen or remove flange bolts while the transmitter is in service.

When properly installed, the flange bolts will protrude through the top of the sensor module housing.

Install flange adapters

Rosemount 3051DP and GP process connections on the transmitter flanges are ¼-18 NPT. Flange adapters are available with standard ½-14 NPT Class 2 connections. Use the flange adapters to disconnect from the process by removing the flange adapter bolts.

⚠ WARNING

Process leaks

Process leaks could result in death or serious injury.

- Install and tighten all four flange bolts before applying pressure.
- Do not attempt to loosen or remove flange bolts while the transmitter is in service.

Use plant-approved lubricant or sealant when making the process connections. Refer to the *Dimensional drawings* section of the Rosemount 3051 [Product Data Sheet](#) for the distance between pressure connections. This distance may be varied $\pm 1/4$ -in. (6.4 mm) by rotating one or both of the flange adapters.

To install adapters to a coplanar flange:

Procedure

1. Remove the flange bolts.

Whenever you remove flanges or adapters, visually inspect the PTFE O-rings. Replace with O-rings designed for Rosemount transmitters if there are any signs of damage, such as nicks or cuts. You may reuse undamaged O-rings. If you replace the O-rings, retorque the flange bolts after installation to compensate for cold flow. Refer to the process sensor body reassembly procedure in [Troubleshooting](#).

Note

Replace PTFE O-rings if you remove the flange adapter.

2. Leaving the flange in place, move the adapters into position with the O-ring installed.
3. Clamp the adapters and the coplanar flange to the transmitter sensor module using the larger of the bolts supplied.
4. Tighten the bolts.
Refer to [Flange bolts](#) for torque specifications.

3.4.4 Inline process connection

Inline gage transmitter orientation

⚠ CAUTION

Erroneous pressure values

The transmitter may output erroneous pressure values.

Do not interfere or block the atmospheric reference port.

The low side pressure port on the inline gage transmitter is located in the neck of the transmitter, behind the housing. The vent path is 360 degrees around the transmitter between the housing and sensor (see [Figure 3-10](#)).

Keep the vent path free of any obstruction, such as paint, dust, and lubrication, by mounting the transmitter so that the process can drain away.

Figure 3-10: Inline Gage Low Side Pressure Port

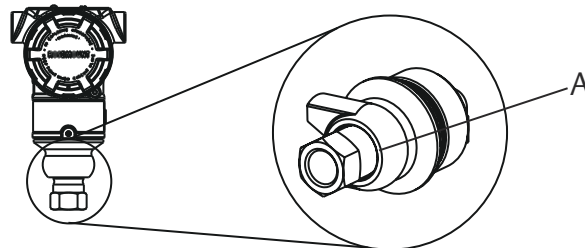

A. Low side pressure port (atmospheric reference)

⚠ CAUTION

Electronics damage

Rotation between the sensor module and the process connection can damage the electronics.

Do not apply torque directly to the sensor module.

To avoid damage, apply torque only to the hex-shaped process connection.

Figure 3-11: Inline Gage

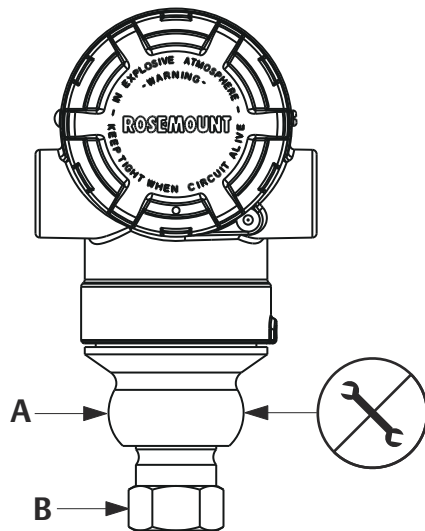

- A. Sensor module
- B. Process connection

Install high pressure coned and threaded connection

The transmitter comes with an autoclave connection designed for pressure applications. Follow the steps below to properly connect the transmitter to your process.

Procedure

1. Apply a process-compatible lubricant to the gland nut threads.
2. Slip the gland nut onto the tube; then thread the collar onto the tube end.
The collar is reverse threaded.
3. Apply a small amount of process-compatible lubricant to the tube cone to help prevent galling and facilitate sealing. Insert the tubing into the connection and use the fingers to tighten the bolts.
4. Tighten the gland nut to a torque of 25 ft-lb.

Note

A weep hole has been designed into the transmitter for safety and leak detection. If fluid begins to leak from the weep hole, isolate the process pressure, disconnect the transmitter, and reseal until the leak is resolved.

3.4.5 Rosemount 305, 306, and 304 Manifolds

The Rosemount 305 Integral Manifold is available in two designs: Traditional and Coplanar. You can mount the traditional Rosemount 305 Integral Manifold to most primary elements with mounting adapters in the market today.

Figure 3-12: Manifolds

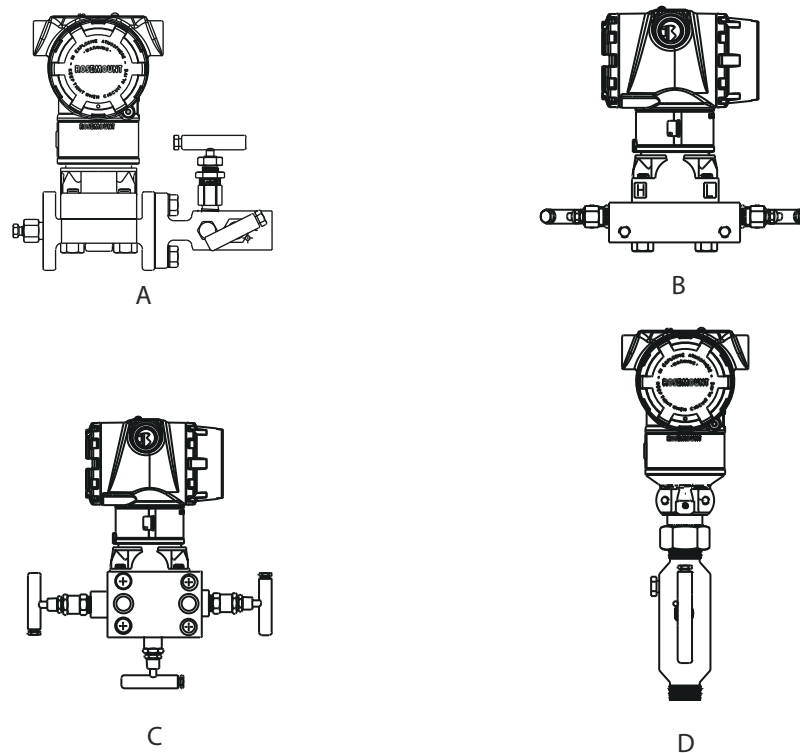

- A. *Rosemount 3051C and 304 Conventional*
 - B. *Rosemount 3051C and 305 Integral Coplanar*
 - C. *Rosemount 3051C and 305 Integral Traditional*
 - D. *Rosemount 3051T and 306 In-Line*
-

The Rosemount 304 Conventional Manifold combines a traditional flange and manifold that you can mount to most primary elements.

Install Rosemount 305 Integral Manifold

Procedure

1. Inspect the PTFE sensor module O-rings.
You may reuse undamaged O-rings. If the O-rings are damaged (if they have nicks or cuts, for example), replace with O-rings designed for Rosemount transmitters.

Important

If replacing the O-rings, take care not to scratch or deface the O-ring grooves or the surface of the isolating diaphragm while you remove the damaged O-rings.

2. Install the Integral Manifold on the sensor module. Use the four 2.25-in. (57.2 mm) manifold bolts for alignment. Finger tighten the bolts; then tighten the bolts incrementally in a cross pattern as seen in [Figure 3-13](#) to final torque value.
See [Flange bolts](#) for complete bolt installation and torque values. When fully tightened, the bolts should extend through the top of the sensor module housing.

Figure 3-13: Bolt Tightening Pattern

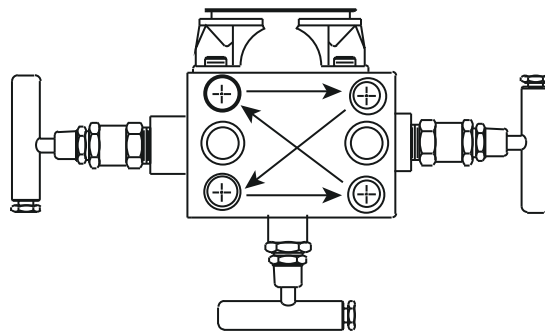

3. If you have replaced the PTFE sensor module O-rings, re-tighten the flange bolts after installation to compensate for cold flow of the O-rings.

Install Rosemount 306 Integral Manifold

Only use the Rosemount 306 Manifold with a Rosemount 3051T In-Line Transmitter.

⚠ WARNING

Process leaks

Process leaks could result in death or serious injury.

Install and tighten process connectors before applying pressure.

Install and tighten all four flange bolts before applying pressure.

Do not attempt to loosen or remove flange bolts while the transmitter is in service.

Assemble the Rosemount 306 Manifold to the Rosemount 3051T In-Line Transmitter with a thread sealant.

Install Rosemount 304 Conventional Manifold

See [Safety messages](#) for complete warning information.

Procedure

1. Align the Conventional Manifold with the transmitter flange. Use the four manifold bolts for alignment.
2. Finger tighten the bolts; then tighten the bolts incrementally in a cross pattern to final torque value.
See [Flange bolts](#) for complete bolt installation information and torque values. When fully tightened, the bolts should extend through the top of the sensor module housing.
3. Leak-check assembly to maximum pressure range of transmitter.

Manifold operation

⚠ WARNING

Process leaks

Process leaks could result in death or serious injury.

Ensure manifolds are installed and operated correctly.

Always perform a zero trim on the transmitter/manifold assembly after installation to eliminate any shift due to mounting effects. See [Sensor trim overview](#).

Operate three and five-valve manifolds

Complete the following steps to perform a zero trim on three and five-valve manifolds.

In normal operation, the two block valves between the process and instrument ports are open, and the equalizing valve is closed.

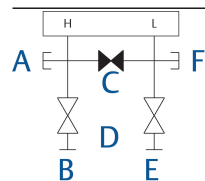

- A. Drain/vent valve
- B. Isolate (open)
- C. Equalize (closed)
- D. Process
- E. Isolate (open)
- F. Drain/vent valve

Procedure

1. To zero the Rosemount 3051, close the block valve to the low pressure (downstream) side first.

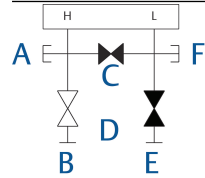

- A. Drain/vent valve
- B. Isolate (open)
- C. Equalize (closed)
- D. Process
- E. Isolate (closed)
- F. Drain/vent valve

2. Open the center (equalize) valve to equalize the pressure on both sides of the transmitter.
The manifold valves are now in the proper configuration for zeroing the transmitter.

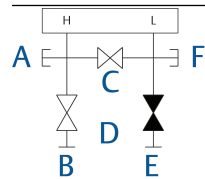

- A. Drain/vent valve
- B. Isolate (open)
- C. Equalize (open)
- D. Process
- E. Isolate (closed)
- F. Drain/vent valve

3. After zeroing the transmitter, close the equalize valve.

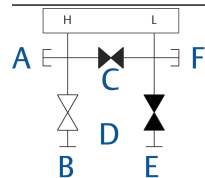

- A. Drain/vent valve
- B. Isolate (open)
- C. Equalize (closed)
- D. Process
- E. Isolate (closed)
- F. Drain/vent valve

4. Open the block valve on the low pressure side of the transmitter to return the transmitter to service.

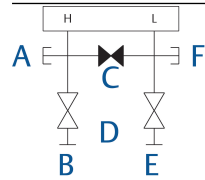

- A. Drain/vent valve
- B. Isolate (open)
- C. Equalize (closed)
- D. Process
- E. Isolate (open)
- F. Drain/vent valve

Operate five-valve natural gas manifold

Complete the following steps to zero a five-valve manifold.

Five-valve natural gas configurations shown:

In normal operation, the two block valves between the process and instrument ports will be open, and the equalizing valves will be closed.

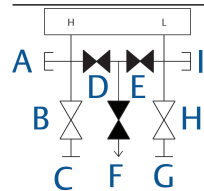

- A. Test (plugged)
- B. Isolate (open)
- C. Process
- D. Equalize (closed)
- E. Equalize (closed)
- F. Drain vent (closed)
- G. Process
- H. Isolate (open)
- I. Test (plugged)

Procedure

1. To zero the Rosemount 3051, first close the block valve on the low pressure (downstream) side of the transmitter.

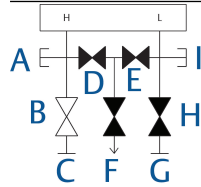

- A. Test (plugged)
- B. Isolate (open)
- C. Process
- D. Equalize (closed)
- E. Equalize (closed)
- F. Drain vent (closed)
- G. Process
- H. Isolate (closed)
- I. Test (plugged)

2. Open the equalize valve on the high pressure (upstream) side of the transmitter.

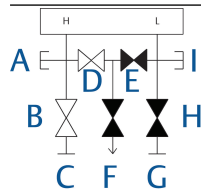

- A. Test (plugged)
- B. Isolate (open)
- C. Process
- D. Equalize (open)
- E. Equalize (closed)
- F. Drain vent (closed)
- G. Process
- H. Isolate (closed)
- I. Test (plugged)

3. Open the equalize valve on the low pressure (downstream) side of the transmitter. The manifold is now in the proper configuration for zeroing the transmitter.

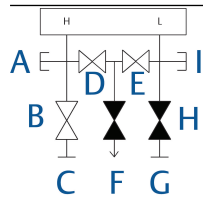

- A. Test (plugged)
- B. Isolate (open)
- C. Process
- D. Equalize (open)
- E. Equalize (open)
- F. Drain vent (closed)
- G. Process
- H. Isolate (closed)
- I. Test (plugged)

4. After zeroing the transmitter, close the equalize valve on the low pressure (downstream) side of the transmitter.

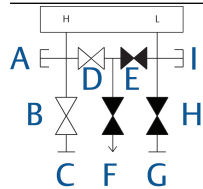

- A. Test (plugged)
- B. Isolate (open)
- C. Process
- D. Equalize (open)
- E. Equalize (closed)
- F. Drain vent (closed)
- G. Process
- H. Isolate (closed)
- I. Test (plugged)

5. Close the equalize valve on the high pressure (upstream) side.

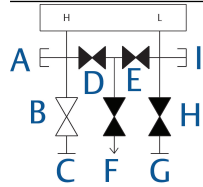

- A. Test (plugged)
- B. Isolate (open)
- C. Process
- D. Equalize (closed)
- E. Equalize (closed)
- F. Drain vent (closed)
- G. Process
- H. Isolate (closed)
- I. Test (plugged)

6. To return the transmitter to service, open the low side isolation valve.

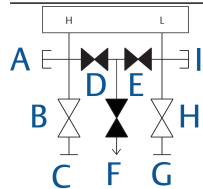

- A. Test (plugged)
 - B. Isolate (open)
 - C. Process
 - D. Equalize (closed)
 - E. Equalize (closed)
 - F. Drain vent (closed)
 - G. Process
 - H. Isolate (open)
 - I. Test (plugged)
-

4 Electrical installation

4.1 Overview

The information in this section covers installation considerations for the Rosemount 3051 Transmitter.

A Quick Start Guide is shipped with every transmitter to describe pipe-fitting, wiring procedures, and basic configuration for initial installation.

Note

For transmitter disassembly and reassembly, refer to [Disassembly procedures](#) and [Reassemble](#).

4.2 Safety messages

Procedures and instructions in this section may require special precautions to ensure the safety of the personnel performing the operations.

⚠ WARNING

Explosions

Explosions could result in death or serious injury.

Installation of device in an explosive environment must be in accordance with appropriate local, national, and international standards, codes, and practices. Review the *Product certifications* section in the Rosemount 3051 [Product Data Sheet](#) for any restrictions associated with a safe installation.

Before connecting a handheld communicator in an explosive atmosphere, ensure the instruments are installed in accordance with intrinsically safe or non-incendive field wiring practices.

In an explosion-proof/flameproof installation, do not remove the transmitter covers when power is applied to the unit.

Process leaks

Process leaks may cause harm or result in death.

Install and tighten process connectors before applying pressure.

Do not attempt to loosen or remove flange bolts while the transmitter is in service.

Electrical shock

Electrical shock can result in death or serious injury.

Avoid contact with the leads and terminals. High voltage that may be present on leads can cause electrical shock.

4.3 LCD display

Emerson ships transmitters ordered with the LCD display option (M5) or Local Operator Interface (LOI) option (M4) with the display installed.

To install the display on an existing Rosemount 3051 Transmitter, you need a small instrument screwdriver. Carefully align the desired display connector with the electronics board connector. If connectors don't align, the display and electronics board are not compatible.

Figure 4-1: LCD Display Assembly

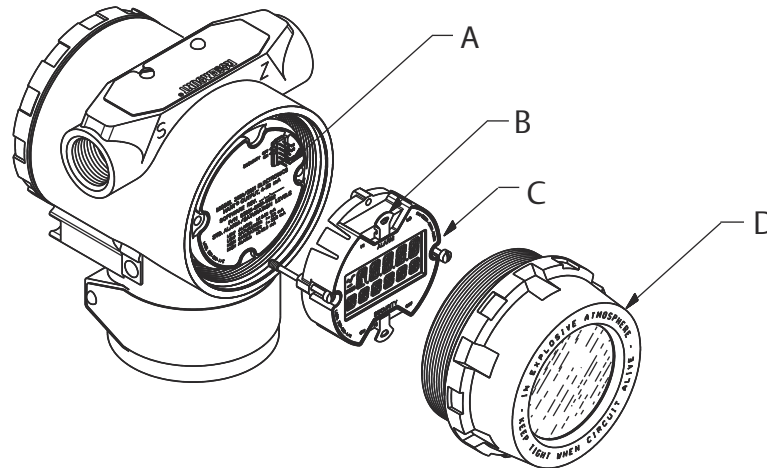

- A. Interconnecting pins
- B. Jumpers (top and bottom)
- C. LCD display
- D. Extended cover

4.3.1 Rotate LOI/LCD display

If you need to rotate the LOI or LCD display after it has been installed on the transmitter, complete the following steps.

Procedure

1. Secure the loop to manual control and remove power to transmitter.

⚠ WARNING

Explosions

Explosions could result in death or serious injury.

Before connecting a handheld communicator in an explosive atmosphere, ensure the instruments are installed in accordance with intrinsically safe or non-incendive field wiring practices.

2. Remove transmitter housing cover.

3. Remove screws from the LOI/LCD display and rotate it to the desired orientation.
 - a) Insert 10 pin connector into the display board for the correct orientation. Carefully align pins for insertion into the output board.
4. Re-insert screws.
5. Reattach transmitter housing cover.
Ensure that the cover is fully engaged to comply with explosion-proof requirements.
6. Re-attach power and return loop to automatic control.

4.4 Configuring transmitter security

There are four security switch methods with the Rosemount 3051 Transmitter.

- Security switch
- HART® lock
- Configuration buttons lock
- LOI password

Figure 4-2: Electronics Board

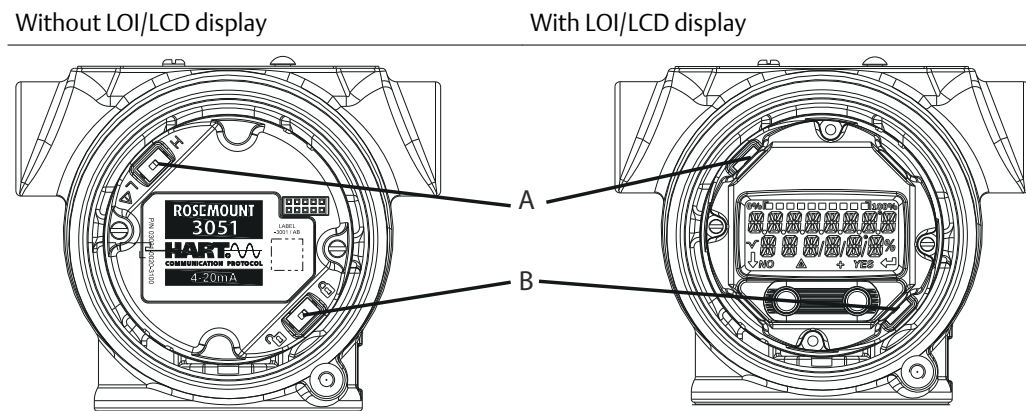

- A. Alarm
- B. Security

4.4.1 Set Security switch

You can use the **Security** switch to prevent changes to the transmitter configuration data.

If you set the **Security** switch to Locked, the transmitter will reject any configuration requests sent via HART®, LOI, or local configuration buttons, and it will not modify the configuration data. Reference [Figure 4-2](#) for the location of the security switch. Follow the steps below to enable the security switch.

Procedure

1. If the transmitter is installed, secure the loop and remove power.

⚠ WARNING

Explosions

Explosions could result in death or serious injury.

In an explosion-proof/flameproof installation, do not remove the transmitter covers when power is applied to the unit.

2. Remove the housing cover opposite the field terminal side.
Do not remove the instrument cover in explosive atmospheres when the circuit is live.
3. Use a small screwdriver to slide the switch to the lock position.
4. Reattach transmitter housing cover.
Emerson recommends tightening the cover until there is no gap between the cover and housing to comply with explosion proof requirements.

4.4.2 Set Simulate switch

The **Simulate** switch is located on the electronics. You can use it in conjunction with the transmitter simulate software to simulate process variables and/or alerts and alarms.

To simulate variables and/or alerts and alarms, move the **Simulate** switch to the Enabled position and enable the software through the host. To disable simulation, move the switch to the Disabled position or disable the software simulate parameter through the host.

4.4.3 HART[®] Lock

The **HART Lock** prevents changes to the transmitter configuration from all sources; it rejects all changes requested via HART, LOI, and local configuration buttons.

You can only set the **HART Lock** via HART communication in HART Revision 7 mode. You can enable or disable the **HART Lock** with a Field Communicator or AMS Device Manager.

Configure HART Lock using Field Communicator

From the **HOME** screen, enter the Fast Key sequence.

Device Dashboard Fast Keys	2, 2, 6, 4
----------------------------	------------

Configure HART Lock using AMS Device Manager

Complete the following steps to enable or disable the **HART Lock** with AMS Device Manager.

Procedure

1. Right-click the device and select Configure.

2. Under **Manual Setup**, select the **Security** tab.
3. Select the **Lock/Unlock** button under **HART Lock (Software)** and follow the screen prompts.

4.4.4 Configuration button lock

The configuration button lock disables all local button functionality.

The transmitter will reject all changes to configuration from the LOI and local buttons. You can only lock local external keys via HART® communication.

Configure Configuration button lock using a Field Communicator

From the **HOME** screen, enter the Fast Key sequence.

Device Dashboard Fast Keys	2, 2, 6, 3
----------------------------	------------

Configure Configuration button lock using AMS Device Manager

Complete the following steps to disable local button functionality with the Configuration button lock.

Procedure

1. Right-click the device and select **Configure**.
2. Under **Manual Setup**, select the **Security** tab.
3. Within the **Configuration Buttons** dropdown menu, select **Disabled** to lock external local keys.
4. Select **Send**.
5. Confirm service reason and select **Yes**.

4.4.5 LOI password

You can enter and enable an LOI password to prevent review and modification of device configuration via the LOI. This does not prevent configuration from HART® or external keys (analog zero and span or digital zero trim).

The LOI password is a four-digit code that you can set. If the password is lost or forgotten, use the master password: 9307.

You can configure and enable or disable the LOI password with HART Communication via a Field Communicator, AMS Device Manager, or the LOI.

Configure LOI password with Field Communicator

From the **HOME** screen, enter the Fast Key sequence.

Device Dashboard Fast Keys	2, 2, 6, 2
----------------------------	------------

Configure LOI password with AMS Device Manager

Procedure

1. Right-click the device and select Configure.
2. Under **Manual Setup**, select the **Security** tab.
3. Within the **Local Operator Interface**, click the **Configure Password** button and follow the screen prompts.

Configure LOI password using Local Operator Interface

On the Local Operator Interface, go to EXTENDED MENU → PASSWORD.

Figure 4-3: LOI Password

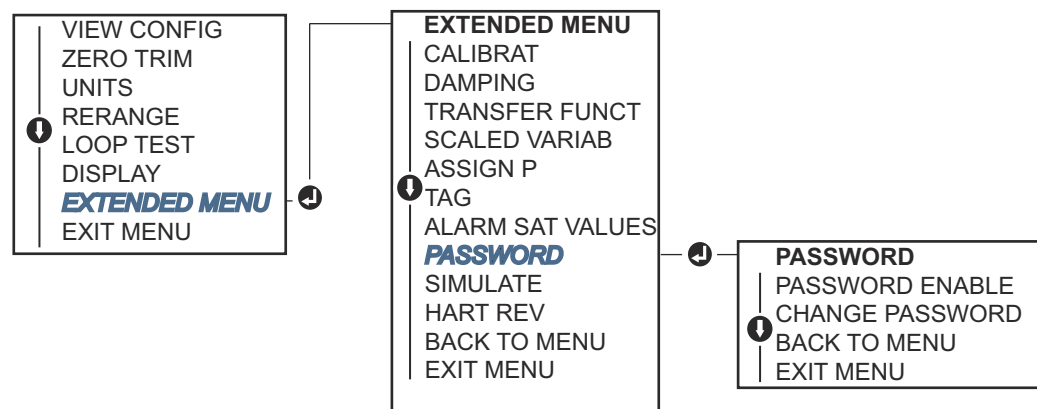

4.5 Set transmitter alarm

There is an alarm switch on the electronics board.

For switch location, see [Figure 4-2](#). Follow the steps below to change the alarm switch location.

Procedure

1. Set loop to manual and remove power.

⚠ WARNING

Explosions

Explosions could result in death or serious injury.

In an explosion-proof/flameproof installation, do not remove the transmitter covers when power is applied to the unit.

2. Remove transmitter housing cover.
3. Use a small screwdriver to slide switch to desired position.
4. Replace transmitter cover.
The cover must be fully engaged to comply with explosion proof requirements.

4.6 Electrical considerations

Note

Make sure all electrical installation is in accordance with national and local code requirements.

⚠ WARNING

Electrical shock

Electrical shock can result in death or serious injury.

Do not run signal wiring in conduit or open trays with power wiring or near heavy electrical equipment.

4.6.1 Conduit installation

⚠ CAUTION

Transmitter damage

If all connections are not sealed, excess moisture accumulation can damage the transmitter.

Mount the transmitter with the electrical housing positioned downward for drainage. To avoid moisture accumulation in the housing, install wiring with a drip loop and ensure the bottom of the drip loop is mounted lower than the conduit connections of the transmitter housing.

Figure 4-4 shows recommended conduit connections.

Figure 4-4: Conduit Installation Diagrams

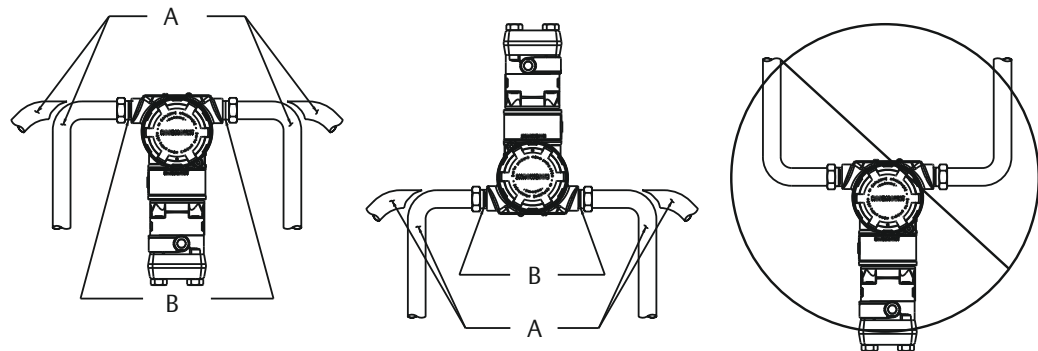

- A. Possible conduit line positions
- B. Sealing compound

4.6.2 Power supply for a 4-20 mA HART

The transmitter operates on 10.5-4.2 Vdc at the terminal of the transmitter. The dc power supply should provide power with less than two percent ripple. Loops with a 250 Ω resistance require a minimum of 16.6 V.

Note

The transmitter must have a minimum of 250 Ω to communicate with a Field Communicator. If you are using a single power supply to power more than one Rosemount 3051 Transmitter, make sure the power supply used and the circuitry common to the transmitters do not have more than 20 Ω of impedance at 1200 Hz.

Figure 4-5: Load Limitation

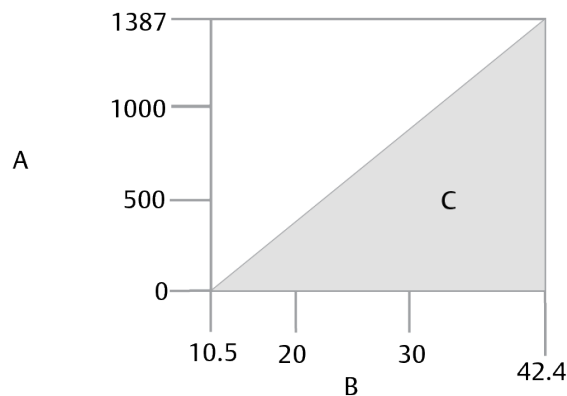

Maximum loop resistance = $43.5 \times (\text{power supply voltage} - 10.5)$

- A. Load (Ω s)
- B. Voltage (Vdc)
- C. Operating region

The total resistance load is the sum of the resistance of the signal leads and the load resistance of the controller, indicator, I.S. barriers, and related pieces. If you use intrinsic safety barriers, include the resistance and voltage drop.

4.6.3 Wire the transmitter

⚠ CAUTION

Equipment damage

Incorrect wiring can damage test circuit.

Do not connect the power signal wiring to the test terminals.

Note

Use shielded twisted pairs to yield best results. To ensure proper communication, use 24 AWG or larger wire and do not exceed 5000 feet (1500 meters).

Figure 4-6: Wiring the Transmitter

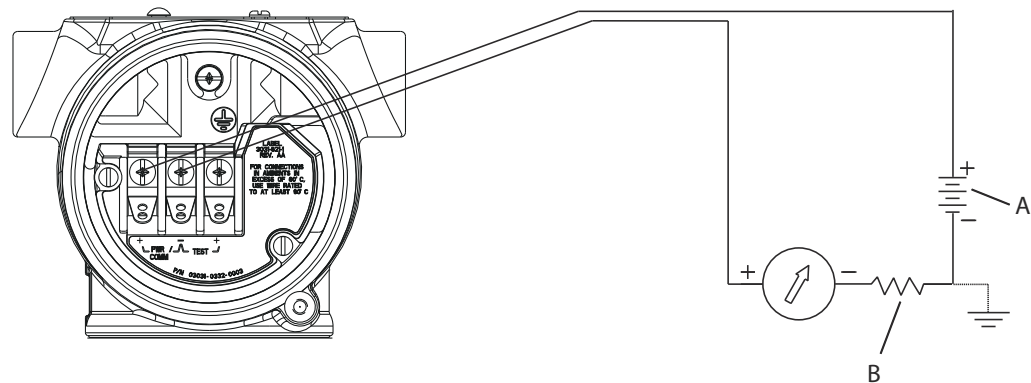

A. DC power supply

B. $R_L \geq 250$ (necessary for HART® Communication only)

Procedure

1. Remove the housing cover on terminal compartment side.

⚠ WARNING

Explosions

Explosions could result in death or serious injury.

In an explosion-proof/flameproof installation, do not remove the transmitter covers when power is applied to the unit.

Signal wiring supplies all power to the transmitter.

2. For a 4-20 mA HART output, connect the positive lead to the terminal marked (pwr/comm+) and the negative lead to the terminal marked (pwr/comm-).

⚠ CAUTION

Equipment damage

Power could damage the test diode.

Do not connect the powered signal wiring to the test terminals.

3. Plug and seal unused conduit connection on the transmitter housing to avoid moisture accumulation on the terminal side.

4.6.4 Ground signal wiring

You must trim and insulate the signal cable shield and unused shield drain wire to ensure that the signal cable shield and drain wire do not come in contact with the transmitter case.

Figure 4-7 summarizes signal cable shield grounding.

Figure 4-7: Wiring Pair and Ground

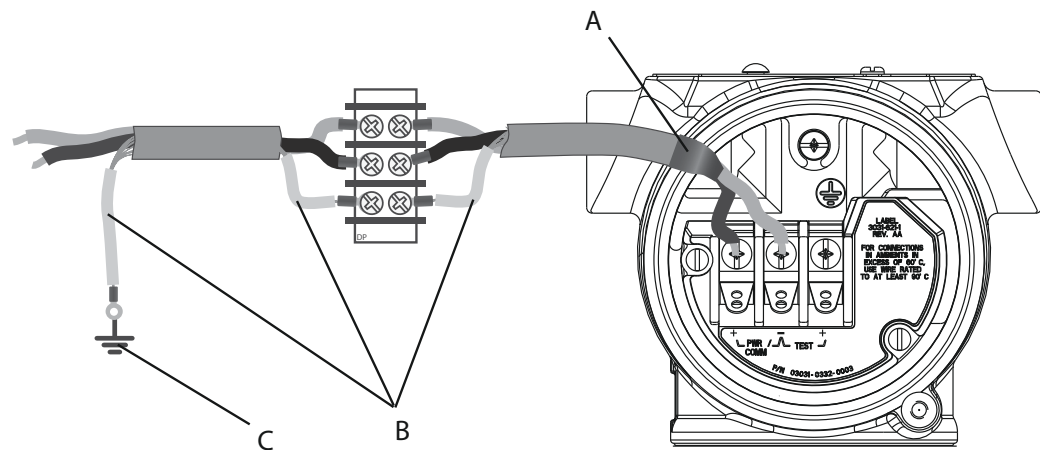

- A. Insulate shield and shield drain wire.
- B. Insulate exposed shield drain wire.
- C. Terminate cable shield drain wire to earth ground.

See [Grounding transmitter case](#) for instructions on grounding the transmitter case. Follow the steps below to correctly ground the signal cable shield.

Procedure

1. Remove the field terminals housing cover.
2. Connect the signal wire pair at the field terminals as indicated in [Figure 4-6](#).
Ensure the cable shield is:
 - Trimmed close and insulated from touching the transmitter housing.
 - Continuously connected to the termination point.

- Connected to a good earth ground at the power supply end.
3. Reattach the field terminals housing cover.
The cover must be fully engaged to comply with explosion-proof requirements.
At terminations outside the transmitter housing, verify the cable shield drain wire is continuously connected.
Prior to the termination point, insulate any exposed shield drain wire as shown in [Figure 4-7 \(B\)](#).
 4. Properly terminate the signal cable shield drain wire to an earth ground at or near the power supply.

Grounding transmitter case

Always ground the transmitter case in accordance with national and local electrical codes. The most effective transmitter case grounding method is a direct connection to earth ground with minimal impedance. Methods for grounding the transmitter case include:

- Internal ground connection: The internal ground connection screw is inside the FIELD TERMINALS side of the electronics housing. This screw is identified by a ground symbol (\oplus). The ground connection screw is standard on all Rosemount 3051 Transmitters. Refer to [Figure 4-8](#).

Figure 4-8: Internal Ground Connection

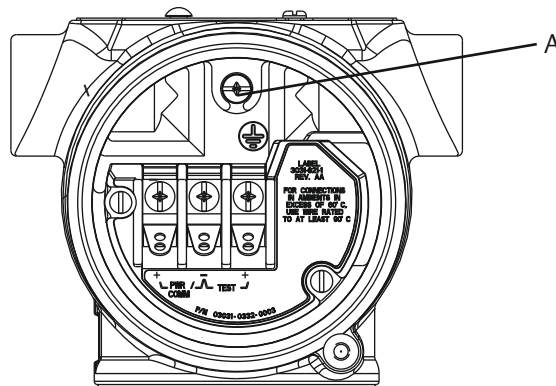

A. Internal ground location

- External ground connection: The external ground connection is located on the exterior of the transmitter housing. Refer to [Figure 4-9](#). This connection is only available with option V5 and T1.

Figure 4-9: External Ground Connection (Option V5 or T1)

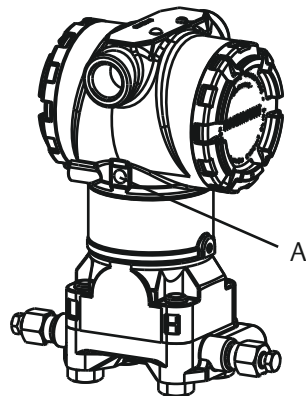

A. External ground location

Note

Grounding the transmitter case via threaded conduit connection may not provide sufficient ground continuity.

Grounding transient protection terminal block

The transmitter can withstand electrical transients of the energy level usually encountered in static discharges or induced switching treatments. However, high-energy transients, such as those induced in wiring from nearby lightning strikes, can damage the transmitter.

You can order the transient protection terminal block as an installed option (option code T1) or as a spare part to retrofit existing transmitters in the field. See the *Spare parts* section of the Rosemount 3051 [Product Data Sheet](#) for part numbers. The lightning bolt symbol shown in [Figure 4-10](#) identifies the transient protection terminal block.

Figure 4-10: Transient Protection Terminal Block

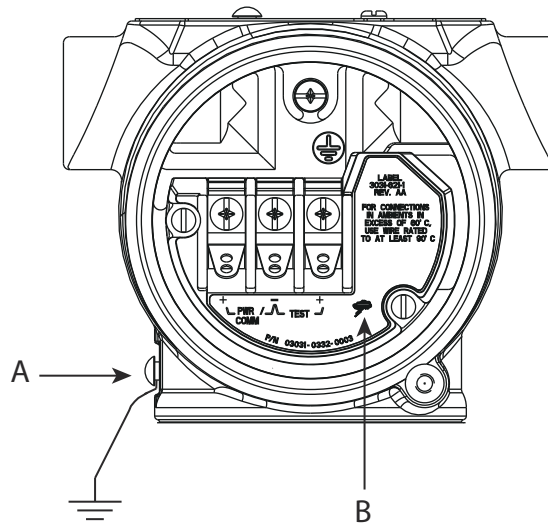

- A. External ground connection location
- B. Lightning bolt connection

Note

The transient protection terminal block does not provide transient protection unless the transmitter case is properly grounded. Use the guidelines to ground the transmitter case. Refer to [Figure 4-10](#).

5 Operation and maintenance

5.1 Overview

⚠ CAUTION

Calibration

It is possible to degrade performance of the transmitter if any trim is done improperly or with inaccurate equipment.

Emerson calibrates absolute pressure transmitters (Rosemount 3051CA and 3051TA) at the factory. Trimming adjusts the position of the factory characterization curve.

This section contains information on calibrating the transmitter. It also provides Field Communicator, AMS Device Manager, and Local Operator Interface (LOI) instructions to perform configuration functions.

5.2 Safety messages

Procedures and instructions in this section may require special precautions to ensure the safety of personnel performing the operations.

⚠ WARNING

Explosions

Explosions could result in death or serious injury.

Installation of device in an explosive environment must be in accordance with appropriate local, national, and international standards, codes, and practices. Please review the *Product certifications* section in the Rosemount 3051 [Product Data Sheet](#) for any restrictions associated with a safe installation.

Before connecting a handheld communicator in an explosive atmosphere, ensure the instruments are installed in accordance with intrinsically safe or non-incendive field wiring practices.

In an explosion-proof/flameproof installation, do not remove the transmitter covers when power is applied to the unit.

Process leaks

Process leaks may cause harm or result in death.

Install and tighten process connectors before applying pressure.

Do not attempt to loosen or remove flange bolts while the transmitter is in service.

⚠ WARNING

Electrical shock

Electrical shock can result in death or serious injury.

Avoid contact with the leads and terminals. High voltage that may be present on leads can cause electrical shock.

Spare parts

Replacement equipment or spare parts not approved by Emerson for use as spare parts could reduce the pressure retaining capabilities of the transmitter and may render the instrument dangerous.

Use only bolts supplied or sold by Emerson as spare parts.

5.3 Recommended calibration tasks

5.3.1 Calibrate in the field

Procedure

1. Perform sensor zero/lower trim; compensate for mounting pressure effects.
Refer to [Manifold operation](#) for instructions on properly draining/venting valves.
2. Set/check basic configuration parameters.
 - Output units
 - Range points
 - Output type
 - Damping value

5.3.2 Calibrate on a bench

Procedure

1. Perform optional 4-20 mA output trim.
2. Perform a sensor trim.
 - a) Zero/lower trim for using line pressure effect correction.
Refer to [Manifold operation](#) for manifold drain/vent valve operation instructions.
 - b) Perform the optional full scale trim.
This sets the span of the device and requires accurate calibration equipment.
 - c) Set/check basic configuration parameters.

Note

To calibrate Rosemount 3051CA and 3051TA range 0 and range 5 devices, you need an accurate absolute pressure source.

5.4 Calibration overview

⚠ CAUTION

Emerson fully calibrates the Rosemount 3051 Pressure Transmitter at the factory. Emerson provides a field calibration option to meet plant requirements or industry standards.

⚠ CAUTION

Sensor calibration allows you to adjust the pressure (digital value) reported by the transmitter to be equal to a pressure standard. The sensor calibration can adjust the pressure offset to correct for mounting conditions or line pressure effects. Emerson recommends this correction. To calibrate the pressure range (pressure span or gain correction) you need accurate pressure standards (sources) to provide full calibration.

There are two parts to complete calibration of the transmitter: sensor calibration and analog output calibration.

Calibrate the sensor

- Perform a sensor trim
- Perform a digital zero trim (option DZ)

Calibrate the 4-20 mA output

- Performing digital-to-analog trim (4-20 mA output trim)
- Performing digital-to-analog trim (4-20 mA output trim) using other scale

5.4.1 Determine necessary sensor trims

With bench calibrations, you can calibrate the instrument for its desired range of operation. Straightforward connections to a pressure source allow for a full calibration at the planned operating points. Exercise the transmitter over the desired pressure range to verify the analog output.

[Trim the pressure signal](#) discusses how the trim operations change the calibration. It is possible to degrade the performance of the transmitter if a trim is done improperly or with inaccurate equipment. You can set the transmitter back to factory settings using the Recall Factory Trim command shown in [Recall factory trim - sensor trim](#).

For transmitters that are field installed, the manifolds discussed in [Rosemount 305, 306, and 304 Manifolds](#) allow the differential transmitter to be zeroed using the zero trim function. [Rosemount 305, 306, and 304 Manifolds](#) discusses both three-valve and five-valve manifolds. This field calibration eliminates any pressure offsets caused by mounting effects (head effect of the oil fill) and static pressure effects of the process.

Determine the necessary trims with the following steps.

Procedure

1. Apply pressure.
2. Check the pressure, if the pressure does not match the applied pressure, perform a sensor trim.
See [Perform a sensor trim](#).
3. Check reported analog output against the live analog output. If they do not match, perform an analog output trim.
See [Performing digital-to-analog trim \(4-20 mA output trim\)](#).

Trimming with configuration buttons

Local configuration buttons are external buttons located underneath the top tag of the transmitter. There are two possible sets of local configuration buttons that you can order and use to perform trim operations: **Digital Zero Trim** and **Local Operator Interface**.

To access the buttons, loosen screw and rotate top tag until buttons are visible.

- **Local Operator Interface (M4)**: Can perform both digital sensor trim and the 4-20 mA output trim (analog output trim). Follow the same procedures listed in trimming with Field Communicator or AMS listed below.
- **Digital zero trim (DZ)**: Performs a sensor zero trim. See [Determine calibration frequency](#) for trim instructions.

Monitor all configuration changes by a display or by measuring the loop output. [Table 5-1](#) shows the physical differences between the two sets of buttons.

Table 5-1: Local Configuration Button Options

LOI - green retainer

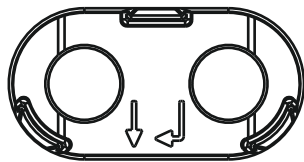

Digital Zero Trim - grey retainer

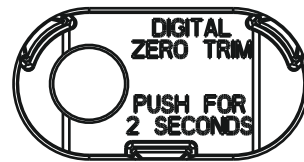

5.4.2 Determine calibration frequency

Calibration frequency can vary greatly depending on the application, performance requirements, and process conditions. To determine calibration frequency:

Procedure

1. Determine the performance required for your application.
2. Determine the operating conditions.
3. Calculate the Total Probable Error (TPE).
4. Calculate the stability per month.
5. Calculate the calibration frequency.

Sample calculation for Rosemount 3051 (0.04 percent accuracy and five-year stability)

The following is an example of how to calculate calibration frequency.

Procedure

1. Determine the performance required for your application.

Required Performance: 0.20% of span

2. Determine the operating conditions.

Transmitter	Rosemount 3051CD, Range 2 [URL=250 inH ₂ O (623 mbar)]
Calibrated span	150 inH ₂ O (374 mbar)
Ambient temperature change	± 50 °F (28 °C)
Line pressure	500 psig (34,5 bar)

3. Calculate total probable error (TPE).

$$\text{TPE} = \sqrt{(\text{ReferenceAccuracy})^2 + (\text{TemperatureEffect})^2 + (\text{StaticPressureEffect})^2} = 0.105\% \text{ of span}$$

Where:

Reference Accuracy = ± 0.04% of span

Ambient Temperature Effect = $\left(\frac{0,0125 \times \text{URL}}{\text{Span}} + 0,0625\right)\%$ per 50 °F = ±0,0833% of span

Span Static Pressure Effect⁽¹⁾ = 0,1% reading per 1000 psi (69 bar) = ±0,05% of span at maximum span

(1) Zero static pressure effect removed by zero trimming at line pressure.

4. Calculate the stability per month.

$$\text{Stability} = \pm \left[\frac{(0,125 \times \text{URL})}{\text{Span}} \right] \% \text{ of span for 5 years} = \pm 0,0021\% \text{ of URL for 1 month}$$

5. Calculate calibration frequency.

$$\text{Cal. Freq.} = \frac{(\text{Req. Performance} - \text{TPE})}{\text{Stability per Month}} = \frac{(0,2\% - 0,105\%)}{0,0021\%} = 45 \text{ months}$$

5.4.3 Compensating for span line pressure effects (range 4 and 5)

Rosemount 2051 Range 4 and 5 Pressure Transmitters require a special calibration procedure when used in differential pressure applications. The purpose of this procedure is

to optimize transmitter performance by reducing the effect of static line pressure in these applications. The Rosemount 3051 Differential Pressure Transmitters (ranges 0 through 3) do not require this procedure because optimization occurs at the sensor.

The systematic span shift caused by the application of static line pressure is -0.95 percent of reading per 1000 psi (69 bar) for Range 4 transmitters and -1 percent of reading per 1000 psi (69 bar) for Range 5 transmitters. Using the following procedure, you can correct the span effect to ± 0.2 percent of reading per 1000 psi (69 bar) for line pressures from 0 to 3626 psi (0 to 250 bar).

Use the following example to compute correct input values.

Example

A Range 4 differential pressure HART® transmitter (Rosemount 3051 CD4...) is used in an application with a static line pressure of 1200 psi (83 bar). The transmitter output is ranged with 4 mA at 500 inH₂O (1,2 bar) and 20 mA at 1500 inH₂O (3,7 bar). To correct for systematic error caused by high static line pressure, first use the following formulas to determine the corrected values for the high trim value.

High trim value

$$HT = (URV - [S/100 \times P/1000 \times LRV])$$

Where:	HT =	Corrected high trim value
	URV =	Upper range value
	S =	Span shift per specification (as a percent of reading)
	P =	Static Line Pressure in psi

In this example:

URV =	1500 inH ₂ O (3.74 bar)
S =	-0.95%
P =	1200 psi
LT =	$1500 - (-0.95\%/100 \times 1200 \text{ psi}/1000 \text{ psi} \times 1500 \text{ inH}_2\text{O})$
LT =	1517.1 inH ₂ O

Complete the upper sensor trim procedure as described in [Perform a sensor trim](#). In the example above, when calculating the stability per month, apply the nominal pressure value of 1500 inH₂O Lo. However, enter the calculated correct upper sensor trim value of 1517.1 inH₂O with a Field Communicator.

Note

The range values for the 4 and 20 mA points should be at the nominal URV and LRV. In the example above, the values are 1500 inH₂O and 500 inH₂O respectively. Confirm the values on the **HOME** screen of the Field Communicator. Modify, if needed, by following the steps in [Rerange the transmitter](#).

5.5 Trim the pressure signal

5.5.1 Sensor trim overview

A sensor trim corrects the pressure offset and pressure range to match a pressure standard. The upper sensor trim corrects the pressure range and the lower sensor trim (zero trim) corrects the pressure offset. An accurate pressure standard is required for full calibration. You can perform a zero trim if the process is vented or the high and low side pressure are equal (for differential pressure transmitters).

Zero trim is a single-point offset adjustment. It is useful for compensating for mounting position effects and is most effective when performed with the transmitter installed in its final mounting position. As this correction maintains the slope of the characterization curve, do not use it in place of a sensor trim over the full sensor range.

When performing a zero trim, ensure that the equalizing valve is open and all wet legs are filled to the correct levels. Apply line pressure to the transmitter during a zero trim to eliminate line pressure errors. Refer to [Manifold operation](#).

Note

Do not perform a zero trim on Rosemount 3051T Absolute Pressure Transmitters. Zero trim is zero based, and absolute pressure transmitters reference absolute zero. To correct mounting position effects on a Rosemount 3051T Absolute Pressure Transmitter, perform a low trim within the sensor trim function. The low trim function provides an offset correction similar to the zero trim function, but it does not require zero-based input.

Upper and lower sensor trim is a two-point sensor calibration where two end-point pressures are applied and all output is linearized between them; this calibration also requires an accurate pressure source. Always adjust the low trim value first to establish the correct offset. Adjustment of the high trim value provides a slope correction to the characterization curve based on the low trim value. The trim values help optimize performance over a specific measurement range.

Figure 5-1: Sensor Trim Example

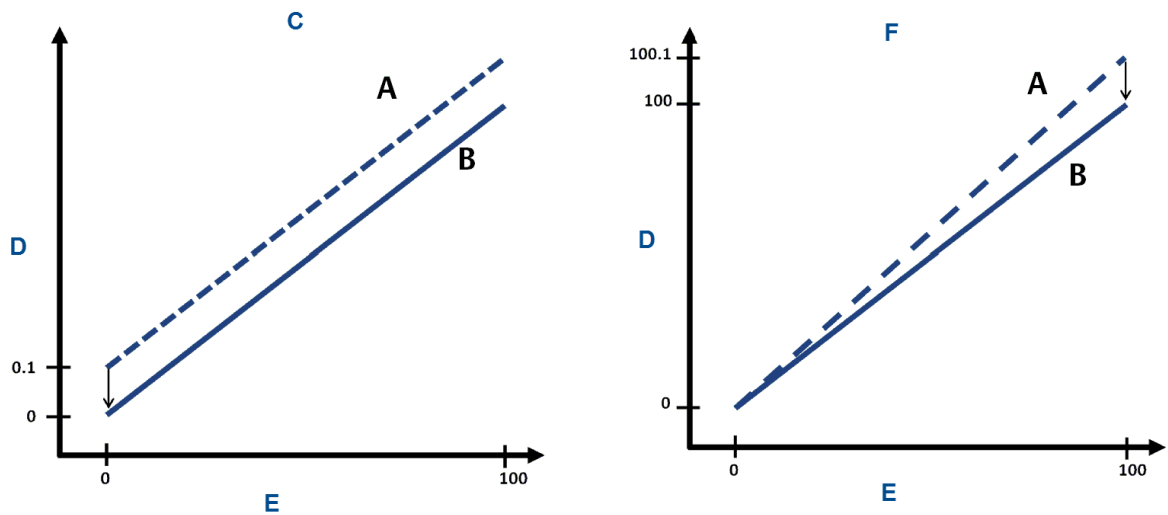

- A. Before trim
- B. After trim
- C. Zero/lower sensor trim
- D. Pressure reading
- E. Pressure input
- F. Upper sensor trim

5.5.2 Recall factory trim - sensor trim

You can use the recall factory trim - sensor trim command to restore the as-shipped factory settings of the sensor trim.

This command can be useful for recovering from an inadvertent zero trim of an absolute pressure unit or inaccurate pressure source.

Recall factory trim with a Field Communicator

From the **HOME** screen, enter the Fast Key sequence and follow the steps within the Field Communicator to complete the sensor trim.

Device Dashboard Fast Keys	3, 4, 3
----------------------------	---------

Recall factory trim with AMS Device Manager

Complete the following steps to restore the sensor trim factory settings with AMS Device Manager.

Procedure

1. Right-click the device. Under the **Method** drop down menu, move cursor over **Calibrate** and select Restore Factory Calibration.
2. Set the control loop to Manual. Then select **Next**.

3. Under *Trim to recall*, select Sensor Trim and click **Next**.
4. Follow the screen prompts to recall sensor trim.

Recall factory trim with LOI

Refer to [Figure 5-2](#) to recall factory sensor trim.

Figure 5-2: Recall Factory Trim - Sensor Trim with LOI

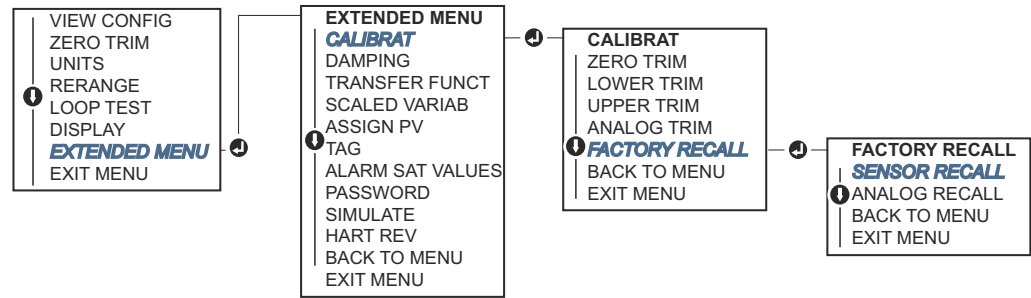

Go to **EXTENDED MENU** → **CALIBRAT** → **FACTORY RECALL** → **SENSOR RECALL**.

5.6 Trim the analog output

You can use the analog output trim command to adjust the transmitter's current output at the 4 and 20 mA points to match the plant standards. Perform this trim after the digital to analog conversion so that it only affects the 4-20 mA analog signal.

[Figure 5-3](#) and [Figure 5-4](#) graphically show the two ways the characterization curve is affected when an analog output trim is performed.

Figure 5-3: 4-20 mA Output Trim - Zero/Lower Trim

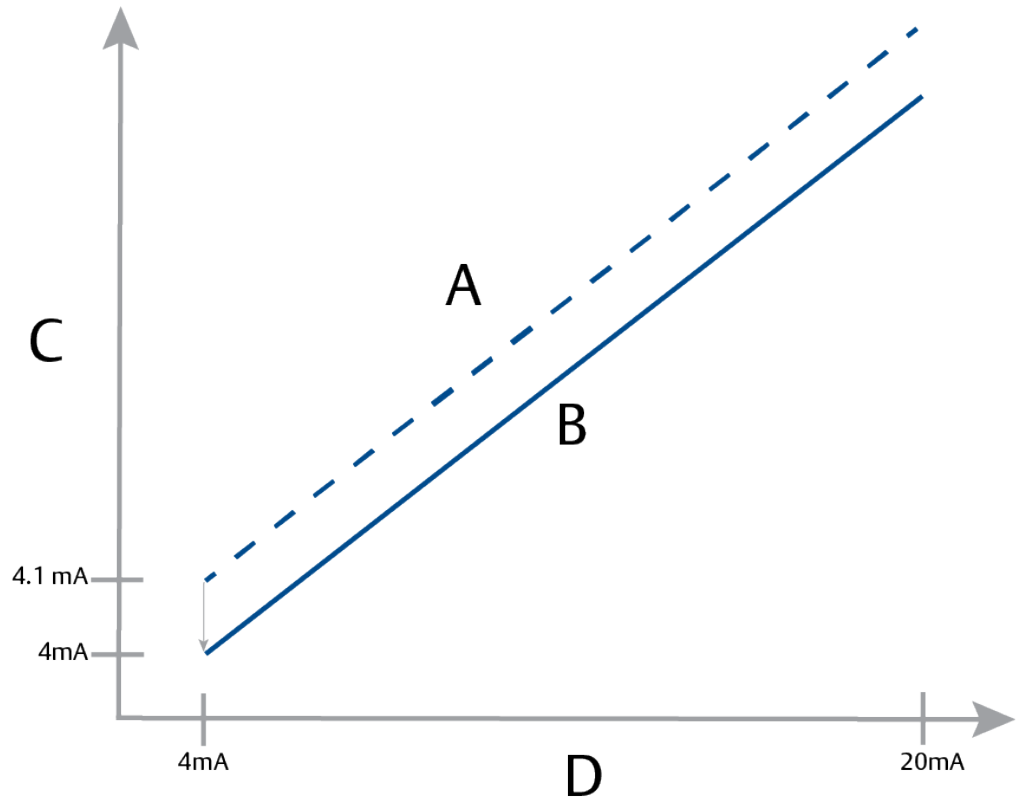

- A. Before trim
- B. After trim
- C. Meter reading
- D. mA output

Figure 5-4: 4-20 mA Output Trim - Upper Trim

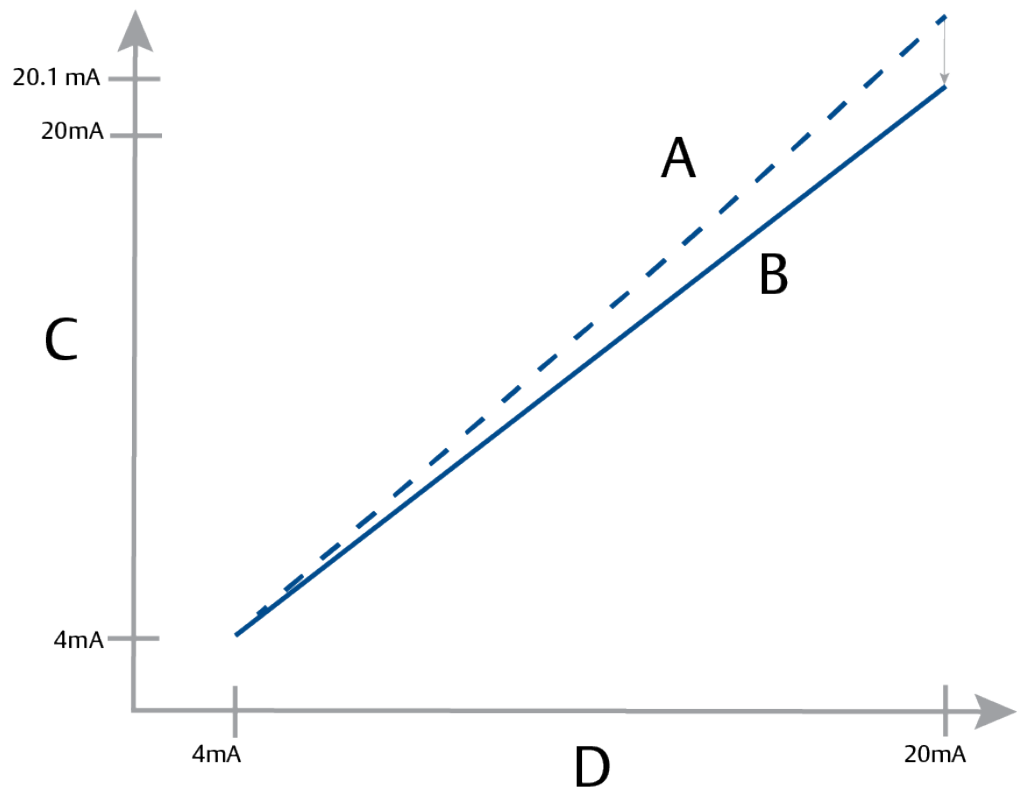

- A. Before trim
- B. After trim
- C. Meter reading
- D. mA output

5.6.1 Performing digital-to-analog trim (4-20 mA output trim)

Note

If you add a resistor to the loop, ensure that the power supply is sufficient to power the transmitter to a 20 mA output with additional loop resistance. Refer to [Power supply for a 4-20 mA HART](#).

Perform a 4-20 mA output trim with a Field Communicator

From the **HOME** screen, enter the Fast Key sequence and follow the steps within the Field Communicator to complete the 4-20 mA output trim.

Device Dashboard Fast Keys	3, 4, 2, 1
----------------------------	------------

Perform a 4-20 mA output trim with AMS Device Manager

Complete the following steps to perform a digital-to-analog trim with AMS Device Manager.

Procedure

1. Right-click the device. Under the **Method** drop down menu, move the cursor over **Calibrate** and select Analog Calibration.
2. Select Digital to Analog Trim.
3. Follow the screen prompts to perform a 4-20 mA output trim.

Perform a 4-20 mA output trim with LOI

Go to EXTENDED MENU → CALIBRAT → ANALOG TRIM.

Figure 5-5: 4-20 mA Output Trim Using LOI

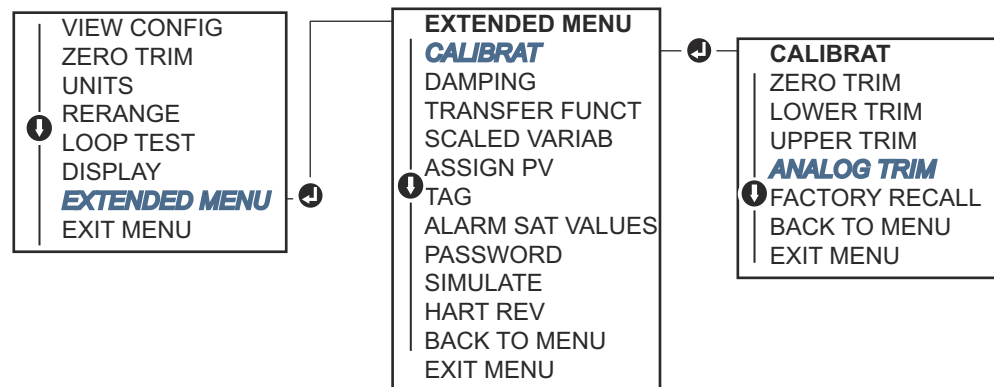

5.6.2 Performing digital-to-analog trim (4-20 mA output trim) using other scale

The scaled 4-20 mA output trim command matches the 4 and 20 mA points to a user selectable reference scale other than 4 and 20 mA (for example, two to ten volts if measuring across a 500 Ω load or 0 to 100 percent if measuring from a Distributed Control System [DCS]).

To perform a scaled 4-20 mA output trim, connect an accurate reference meter to the transmitter and trim the output signal to scale as outlined in the output trim procedure.

Perform a 4-20 mA output trim using other scale with a Field Communicator

From the **HOME** screen, enter the Fast Key sequence and follow the steps within the Field Communicator to complete the 4-20 mA output trim using other scale.

Device Dashboard Fast Keys	3, 4, 2, 2
----------------------------	------------

Perform a 4-20 mA output trim using other scale with AMS Device Manager

Complete the following steps to perform a scaled 4-20 mA output trim with AMS Device Manager.

Procedure

1. Right-click the device. Under the **Method** drop down menu, move cursor over **Calibrate** and select Analog Calibration.
2. Select Scaled Digital to Analog Trim.
3. Follow screen prompts to perform a 4-20 mA output trim.

5.6.3 Recalling factory trim - analog output

You can use the recall factory trim - analog output command to restore the as-shipped factory settings to the analog output trim.

This command can be useful for recovering from an inadvertent trim, incorrect plant standard, or faulty meter.

Recall factory trim - analog output with a Field Communicator

From the **HOME** screen, enter the Fast Key sequence and follow the steps within the Field Communicator to restore the analog output trim to factory settings.

Device Dashboard Fast Keys	3, 4, 3
----------------------------	---------

Recall factory trim - analog output with AMS Device Manager

Complete the following steps to restore the analog output trim to factory settings using AMS Device Manager.

Procedure

1. Right-click the device. Under the **Method** drop down menu, move cursor over **Calibrate**, and select Restore Factory Calibration.
2. Select **Next** to set the control loop to manual.
3. Under **Select trim to recall**, select Analog Output Trim and click **Next**.
4. Follow screen prompts to recall analog output trim.

Recall factory trim - analog output with LOI

Reference [Figure 5-6](#) for LOI instructions.

Figure 5-6: Recall Factory Trim - Analog Output with LOI

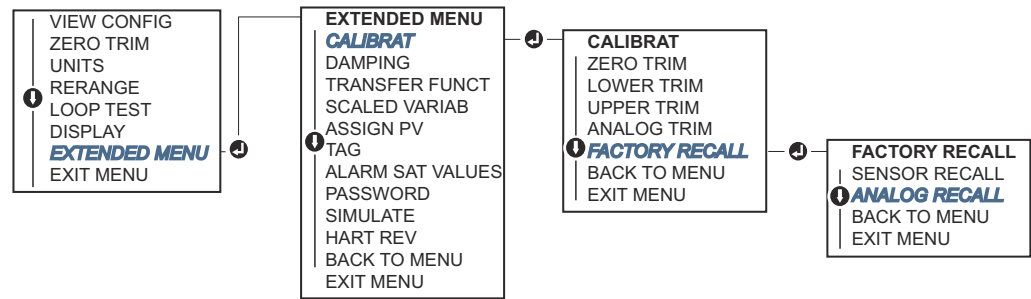

Go to **EXTENDED MENU** → **CALIBRAT** → **FACTORY RECALL** → **ANALOG RECALL**.

5.7 Switching HART® revision

Some systems are not capable of communicating with HART Revision 7 devices. The following procedures list how to change HART revisions between HART Revision 7 and HART Revision 5.

5.7.1 Switch HART revision with generic menu

If the HART configuration tool cannot communicate with a HART Revision 7 device, it loads a generic menu with limited capability. The following procedure explains how to switch between HART Revision 7 and HART Revision 5 from a generic menu.

Locate Message field.

- To change to HART Revision 5, enter HART5 in the Message field.
- To change to HART Revision 7, enter HART7 in the Message field.

5.7.2 Switch HART revision with Field Communicator

From the **HOME** screen, enter the Fast Key sequence and follow steps within the Field Communicator to complete the HART revision change.

	HART 5	HART 7
Device Dashboard Fast Keys	2, 2, 5, 2, 4	2, 2, 4, 2, 3

5.7.3 Switch HART revision with AMS Device Manager

Complete the following steps to change the transmitter's HART revision with AMS Device Manager.

Procedure

1. Select **Manual Setup** and select HART.
2. Select **Change HART Revision**; then follow the screen prompts.

5.7.4 Switch HART revision with LOI

Navigate to HART Rev within the extended menu and select either HART Rev 5 or HART Rev 7.

Use [Figure 5-7](#) to change HART revision.

Figure 5-7: Change HART Revision with LOI

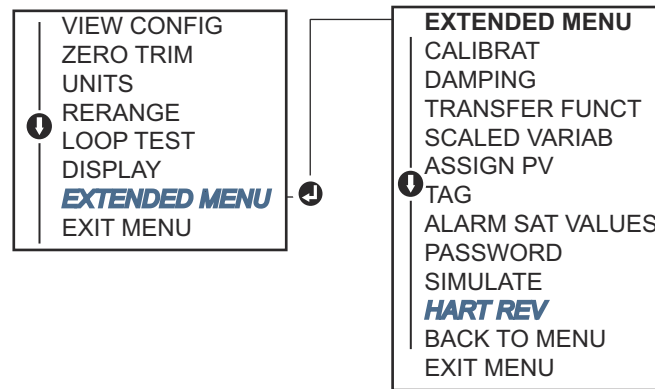

6 Troubleshooting

6.1 Overview

This section provides summarized troubleshooting suggestions for the most common operating problems.

If you suspect malfunction despite the absence of any diagnostic messages on the Field Communicator display, consider using [Diagnostic messages](#) to identify any potential problem.

6.2 Safety messages

Procedures and instructions in this section may require special precautions to ensure the safety of personnel performing the operations.

⚠ WARNING

Explosions

Explosions could result in death or serious injury.

Installation of device in an explosive environment must be in accordance with appropriate local, national, and international standards, codes, and practices. Please review the *Product certifications* section in the Rosemount 3051 [Product Data Sheet](#) for any restrictions associated with a safe installation.

Before connecting a handheld communicator in an explosive atmosphere, ensure the instruments are installed in accordance with intrinsically safe or non-incendive field wiring practices.

In an explosion-proof/flameproof installation, do not remove the transmitter covers when power is applied to the unit.

Process leaks

Process leaks may cause harm or result in death.

Install and tighten process connectors before applying pressure.

Do not attempt to loosen or remove flange bolts while the transmitter is in service.

⚠ WARNING

Electrical shock

Electrical shock can result in death or serious injury.

Avoid contact with the leads and terminals. High voltage that may be present on leads can cause electrical shock.

⚠ WARNING

Spare parts

Replacement equipment or spare parts not approved by Emerson for use as spare parts could reduce the pressure retaining capabilities of the transmitter and may render the instrument dangerous.

Use only bolts supplied or sold by Emerson as spare parts.

6.3 Troubleshooting for 4-20 mA output

6.3.1 Transmitter milliamp reading is zero

Recommended actions

1. Verify terminal voltage is 10.5 to 42.4 Vdc at signal terminals.
2. Check power wires for reversed polarity.
3. Check that power wires are connected to signal terminals.
4. Check for open diode across test terminal.

6.3.2 Transmitter not communicating with Field Communicator

Recommended actions

1. Verify terminal voltage is 10.5 to 42.2 Vdc.
2. Check loop resistance, 250 Ω minimum (PS voltage - transmitter voltage/loop current).
3. Check that power wires are connected to signal terminals and not test terminals.
4. Verify clean DC power to transmitter (maximum AC noise 0.2 volts peak to peak).
5. Verify the output is between 4 and 20 mA or saturation levels.
6. Have Field Communicator poll for all addresses.

6.3.3 Transmitter milliamp reading is low or high

Recommended actions

1. Verify applied pressure.
2. Verify 4 and 20 mA range points.
3. Verify output is not in alarm condition.
4. Perform analog trim.
5. Check that power wires are connected to the correct signal terminals (positive to positive, negative to negative) and not the test terminal.

6.3.4 Transmitter will not respond to changes in applied pressure

Recommended actions

1. Check impulse piping or manifold for blockage.
2. Verify applied pressure is between 4 and 20 mA points.
3. Verify the output is not in alarm condition.
4. Verify transmitter is not in loop test mode.
5. Verify transmitter is not in multidrop mode.
6. Check test equipment.

6.3.5 Digital pressure variable reading is low or high

Recommended actions

1. Check impulse piping for blockage or low fill in wet leg.
2. Verify transmitter is calibrated properly.
3. Check test equipment (verify accuracy).
4. Verify pressure calculations for application.

6.3.6 Digital pressure variable reading is erratic

Recommended actions

1. Check application for faulty equipment in pressure line.
2. Verify transmitter is not reacting directly to equipment turning on/off.
3. Verify damping is set properly for application.

6.3.7 Milliamp reading is erratic

Recommended actions

1. Verify power source to transmitter has adequate voltage and current.
2. Check for external electrical interference.
3. Verify transmitter is properly grounded.
4. Verify shield for twisted pair is only grounded at one end.

6.4 Diagnostic messages

The below sections contain possible messages that appear on either the LOI/LCD display, a Field Communicator, or an AMS system. Use them to diagnose particular status messages.

- Good
- Failed - fix now

- Maintenance - fix soon
- Advisory

6.4.1 Diagnostic message: Failed - fix now

No pressure updates

LCD display screen NO P UPDATE

Local operator interface (LOI) screen NO PRESS UPDATE

There are no pressure updates from the sensor to the electronics.

Recommended actions

1. Ensure the sensor cable connection to the electronics is tight.
2. Replace the pressure sensor.

Electronics board failure

LCD display screen FAIL BOARD

Local operator interface (LOI) screen FAIL BOARD

A failure has been detected in the electronics circuit board.

Recommended action

Replace the electronics board.

Critical sensor data error

LCD display screen MEMRY ERROR

Local operator interface (LOI) screen MEMORY ERROR

A user-written parameter does not match the expected value.

Recommended actions

1. Confirm and correct all parameters listed in *Device Information*.
2. Perform a device reset.
3. Replace sensor module.

Critical electronics data error

LCD display screen MEMRY ERROR

Local operator interface (LOI) screen MEMORY ERROR

A user-written parameter does not match the expected value.

Recommended actions

1. Confirm and correct all parameters listed in *Device Information*.
2. Perform a device reset.
3. Replace electronics board.

Sensor failure

LCD display screen FAIL SENSOR

Local operator interface (LOI) screen FAIL SENSOR

A failure has been detected in the pressure sensor.

Recommended action

Replace the pressure sensor.

Incompatible electronics and sensor

LCD display screen XMTR MSMTCH

Local operator interface (LOI) screen XMTR MSMTCH

The pressure sensor is incompatible with the attached electronics.

Recommended action

Replace the electronics board or sensor with compatible hardware.

6.4.2 Diagnostic message: Maintenance - fix soon

No temperature updates

LCD display screen NO T UPDATE

Local operator interface (LOI) screen NO TEMP UPDATE

There are no temperature updates from the sensor to the electronics.

Recommended actions

1. Ensure the sensor cable connection to the electronics is tight.
2. Replace the pressure sensor.

Pressure out of limits

LCD display screen NO T UPDATE

Local operator interface (LOI) screen PRES OUT LIMITS

The pressure is either above or below the sensor limits.

Recommended actions

1. Check the transmitter pressure connection to ensure it is not plugged and the isolating diaphragms are not damaged.
2. Replace the pressure sensor.

Sensor temperature beyond limits

LOI display screen TEMP LIMITS

Local operator interface (LOI) screen TEMP OUT LIMITS

The sensor temperature has exceeded its safe operating range.

Recommended actions

1. Check the process and ambient conditions are within -85 to 194 °F (-65 to 90 °C).
2. Replace the pressure sensor.

Electronics temperature beyond limits

LCD display screen TEMP LIMITS

Local operator interface (LOI) screen TEMP OUT LIMITS

The temperature of the electronics has exceeded its safe operating range.

Recommended actions

1. Confirm electronics temperature is within limits of -85 to 194 °F (-65 to 90 °C).
2. Replace electronics board.

Power advisory diagnostic

LCD screen: POWER ADVISE, LOI screen: POWER ADVISE

The transmitter has detected a deviation of the terminal voltage outside of configured limits. This may indicate degraded electrical or loop integrity.

Recommended actions

1. Check the dc power supply to ensure power is correct, stable, and has minimal ripple.
2. Check loop wiring for degradation or improper grounding.
3. Remove the wiring compartment cover (considering hazardous location requirements) to check for presence of water or corrosion.

Note

If conditions have returned to normal, select **Reset Alert** to clear the alert.

Electronics board parameter error

LCD display screen MEMRY WARN (also in advisory)

Local operator interface (LOI) screen MEMORY WARN (also in advisory)

A device parameter does not match the expected value. The error does not affect transmitter operation or analog output.

Recommended action

Replace the electronics board.

Configuration buttons operator error

LCD display screen STUCK BUTTON

Local operator interface (LOI) screen STUCK BUTTON

Device is not responding to button presses.

Recommended actions

1. Check configuration buttons are not stuck.
2. Replace the electronics board.

6.4.3 Diagnostic message: Advisory

Non-critical user data warning

LCD display screen MEMRY WARN

Local operator interface (LOI) screen MEMORY WARN

A user-written parameter does not match expected value.

Recommended actions

1. Confirm and correct all parameters listed in *Device Information*.
2. Perform a Device Reset.
3. Replace electronics board.

Sensor parameter warning

LCD display screen MEMRY WARN

Local operator interface (LOI) screen MEMORY WARN

A user-written parameter does not match expected value.

Recommended actions

1. Confirm and correct all parameters listed in *Device Information*.
2. Perform a Device Reset.
3. Replace pressure sensor.

Pressure alert

LCD screen: PRESS ALERT, LOI screen: PRESSURE ALERT

The pressure alert diagnostic has gone beyond the configured trip points.

Recommended actions

1. Verify that the process pressure is at an expected value.
2. Verify the pressure is beyond the trip points.
3. Modify the trip points or turn off alert.

Temperature alert

LCD screen: TEMP ALERT, LOI screen: TEMP ALERT

The temperature alert diagnostic has detected that the temperature has gone beyond the configured trip points.

Recommended actions

1. Verify that the process and environmental temperature is at an expected value.
2. Verify the temperature is beyond the trip points.
3. Modify the trip points or turn off alert.

LCD display update failure

LCD display screen (Not updating)

Local operator interface (LOI) screen (Not updating)

The LCD display is not receiving updates from the pressure sensor.

Recommended actions

1. Check the connection between the LCD and the circuit board.
2. Replace the LCD display.

Configuration changed

LCD display screen (None)

Local operator interface (LOI) screen (None)

A recent change has been made to the device by a secondary HART® master, such as a handheld device.

Recommended actions

1. Verify that the configuration change of the device was intended and expected.
2. Clear this alert by selecting **Clear Configuration Changed Status**.
3. Connect a HART master, such as AMS or similar, which will automatically clear the alert.

Analog output fixed

LCD display screen ANALOG FIXED

Local operator interface (LOI) screen ANALOG FIXED

The analog output is fixed and does not represent the process measurement.

This may be caused by other conditions in the device or because the device has been set to loop test or multidrop mode.

Recommended actions

1. Take action on any other notifications from the device.
2. If the device is in a loop test and should no longer be, disable or momentarily remove power.
3. If the device is in multidrop mode and should not be, re-enable loop current by setting the polling address to 0.

Simulation active

LCD display screen (None)

Local operator interface (LOI) screen (None)

The device is in simulation mode and may not be reporting actual information.

Recommended actions

1. Verify that simulation is no longer required.
2. Disable simulation mode in service tools.
3. Perform a Device Reset.

Analog output saturated

LCD display screen ANLOG SAT

Local operator interface (LOI) screen ANALOG SAT

The analog output is saturated either high or low due to the pressure either above or below the range values.

Recommended actions

1. Check the pressure applied to ensure it is between the 4 and 20 mA points.
2. Check the transmitter pressure connection to ensure it is not plugged and the isolating diaphragms are not damaged.
3. Replace the pressure sensor.

6.5 Disassembly procedures

⚠ WARNING

Explosion

Explosions could result in death or serious injury.

Do not remove the instrument cover in explosive atmospheres when the circuit is live.

6.5.1 Remove from service

Follow these steps:

Procedure

1. Follow all plant safety rules and procedures.
2. Power down device.
3. Isolate and vent the process from the transmitter before removing the transmitter from service.
4. Remove all electrical leads and disconnect conduit.
5. Remove the transmitter from the process connection.
 - The Rosemount 3051C Transmitter is attached to the process connection by four bolts and two cap screws. Remove the bolts and screws and separate the transmitter from the process connection. Leave the process connection in place and ready for reinstallation. Reference [Figure 3-4](#) for coplanar flange.
 - The Rosemount 3051T Transmitter is attached to the process by a single hex nut process connection. Loosen the hex nut to separate the transmitter from the process. Do not wrench on neck of transmitter. See warning in [Inline gage transmitter orientation](#).
6. Do not scratch, puncture, or depress the isolating diaphragms.
7. Clean isolating diaphragms with a soft rag and a mild cleaning solution, and rinse with clear water.
8. For the Rosemount 3051C, whenever you remove the process flange or flange adapters, visually inspect the PTFE O-rings. Replace the O-rings if they show any signs of damage, such as nicks or cuts.
You may reuse undamaged O-rings.

6.5.2 Remove terminal block

Electrical connections are located on the terminal block in the compartment labeled FIELD TERMINALS.

Procedure

1. Remove the housing cover from the field terminal side.
2. Loosen the two small screws located on the assembly in the 9 o'clock and 5 o'clock positions relative to the top of the transmitter.

3. Pull the entire terminal block out to remove it.

6.5.3 Remove electronics board

The transmitter electronics board is located in the compartment opposite the terminal side.

Procedure

1. Remove the housing cover opposite the field terminal side.
2. If you are disassembling a transmitter with an LOI/LCD display, loosen the two captive screws that are visible on the meter display.

See [#unique_156/unique_156_Connect_42_RFIXbr67255](#) for screw locations. The two screws anchor the LOI/LCD display to the electronics board and the electronics board to the housing.

Note

The electronics board is electrostatically sensitive; observe handling precautions for static-sensitive components.

3. **Note**
If an LOI/LCD display is installed, use caution as there is an electronic pin connector that interfaces between the LOI/LCD display and electronics board.
-

6.5.4 Remove sensor module from the electronics housing

Procedure

1. Remove the electronics board.
Refer to [Remove electronics board](#).

Important

To prevent damage to the sensor module ribbon cable, disconnect it from the electronics board before you remove the sensor module from the electrical housing.

2. Carefully tuck the cable connector completely inside of the internal black cap.

Note

Do not remove the housing until after you tuck the cable connector completely inside of the internal black cap. The black cap protects the ribbon cable from damage that can occur when you rotate the housing.

3. Using a 5/64-in. hex wrench, loosen the housing rotation set screw one full turn.
4. Unscrew the module from the housing, making sure the black cap on the sensor module and sensor cable do not catch on the housing.

6.6 Reassemble

Complete the following steps to reassemble the transmitter.

Procedure

1. Inspect all cover and housing (non-process wetted) O-rings and replace if necessary. Lightly grease with silicone lubricant to ensure a good seal.
2. Carefully tuck the cable connector completely inside the internal black cap. To do so, turn the black cap and cable counterclockwise one rotation to tighten the cable.
3. Lower the electronics housing onto the module. Guide the internal black cap and cable on the sensor module through the housing and into the external black cap.
4. Turn the module clockwise into the housing.

Important

Ensure the sensor ribbon cable and internal black cap remain completely free of the housing as you rotate it. Damage can occur to the cable if the internal black cap and ribbon cable become hung up and rotate with the housing.

5. Thread the housing completely onto the sensor module.
The housing must be no more than one full turn from flush with the sensor module to comply with explosion proof requirements. See [Safety messages](#) for complete warning information.
6. Tighten the housing rotation set screw using a 5/64-in. wrench.

6.6.1 Attach electronics board

Complete the following steps to attach the transmitter's electronics board.

Procedure

1. Remove the cable connector from its position inside of the internal black cap and attach it to the electronics board.
2. Using the two captive screws as handles, insert the electronics board into the housing.
Ensure the power posts from the electronics housing properly engage the receptacles on the electronics board. Do not force. The electronics board should slide gently on the connections.
3. Tighten the captive mounting screws.
4. Replace the electronics housing cover.

⚠ WARNING

Explosions

Explosions could result in death or serious injury.

In an explosion-proof/flameproof installation, do not remove the transmitter covers when power is applied to the unit.

The transmitter covers must be engaged metal-to-metal to ensure a proper seal and to meet explosion-proof requirements.

6.6.2 Install terminal block

Complete the following steps to reinstall the terminal block into the transmitter.

Procedure

1. Gently slide the terminal block into place, making sure the two power posts from the electronics housing properly engage the receptacles on the terminal block.

⚠ WARNING

Electrical shock

Electrical shock can result in death or serious injury.

Avoid contact with the leads and terminals. High voltage that may be present on leads can cause electrical shock.

2. Tighten the captive screws.
3. Replace the electronics housing cover.

⚠ WARNING

Explosions

Explosions could result in death or serious injury.

The transmitter covers must be fully engaged to meet Explosion-Proof requirements.

6.6.3 Reassemble the Rosemount 3051C process flange

Complete the following steps to reassemble the Rosemount 3051C process flange.

Procedure

1. Inspect the sensor module PTFE O-rings.
You may reuse undamaged O-rings. Replace O-rings that show any signs of damage, such as nicks, cuts, or general wear.

Note

If you are replacing the O-rings, be careful not to scratch the O-ring grooves or the surface of the isolating diaphragm when removing the damaged O-rings.

2. Install the process connection. Possible options include:
 - Coplanar process flange:
 - a. Hold the process flange in place by installing the two alignment screws to finger tightness (screws are not pressure retaining). Do not overtighten as this will affect module-to-flange alignment.
 - b. Install the four 1.75-in. flange bolts by finger tightening them to the flange.
 - Coplanar process flange with flange adapters:
 - a. Hold the process flange in place by installing the two alignment screws to finger tightness (screws are not pressure retaining). Do not overtighten as this will affect module-to-flange alignment.
 - b. Hold the flange adapters and adapter O-rings in place while installing (in the desired of the four possible process connection spacing configurations) using four 2.88-in. bolts to mount securely to the coplanar flange. For gage pressure configurations, use two 2.88-inch bolts and two 1.75-in. bolts.
 - Manifold: Contact the manifold manufacturer for the appropriate bolts and procedures.
3. Tighten the bolts to the initial torque value using a crossed pattern.
See [Table 6-1](#) for appropriate torque values.
4. Using the same cross pattern, tighten bolts to final torque values seen in [Table 6-1](#).

Table 6-1: Bolt Installation Torque Values

Bolt material	Initial torque value	Final torque value
CS-ASTM-A445 Standard	300 in.-lb (34 N-m)	650 in.-lb (73 N-m)
316 SST—Option L4	150 in.-lb (17 N-m)	300 in.-lb (34 N-m)
ASTM-A-19 B7M—Option L5	300 in.-lb (34 N-m)	650 in.-lb (73 N-m)
ASTM-A-193 Class 2, Grade B8M—Option L8	150 in.-lb (17 N-m)	300 in.-lb (34 N-m)

Note

If you replaced the PTFE sensor module O-rings, re-torque the flange bolts after installation to compensate for cold flow of the O-ring material.

Note

For Range 1 transmitters, after replacing O-rings and re-installing the process flange, expose the transmitter to a temperature of 185 °F (85 °C) for two hours. Then re-tighten the flange bolts in a cross pattern and again expose the transmitter to a temperature of 185 °F (85 °C) for two hours before calibration.

See [Safety messages](#) for complete warning information.

6.6.4 Install drain/vent valve

Complete the following steps to reinstall the drain/vent valve in the Rosemount 3051 Transmitter.

Procedure

1. Apply sealing tape to the threads on the seat. Starting at the base of the valve with the threaded end pointing toward the installer, apply five clockwise turns of sealing tape.
2. Tighten the drain/vent valve to 250 in.-lb. (28.25 N-m).
3. Take care to place the opening on the valve so that process fluid will drain toward the ground and away from human contact when the valve is opened.

6.7 Service support

Within the United States, call the Emerson Instrument and Valve Response Center using the 1-800-654-RSMT (7768) toll-free number. This center, available 24 hours a day, will assist you with any needed information or materials.

The center will ask for product model and serial numbers and will provide a Return Material Authorization (RMA) number. The center will also ask for the process material to which the product was last exposed.

For inquiries outside of the United States, contact the nearest Emerson representative for RMA instructions.

To expedite the return process outside of the United States, contact the nearest Emerson representative.

⚠ WARNING

Hazardous substances

Individuals who handle products exposed to a hazardous substance may be injured.

You can avoid injury by learning about and understanding the hazard.

Include a copy of the required Material Safety Data Sheet (MSDS) for each substance with the returned goods.

Emerson Instrument and Valve Response Center representatives will explain the additional information and procedures necessary to return goods exposed to hazardous substances.

7 Safety Instrumented Systems (SIS) requirements

A two-wire, 4-20 mA signal representing pressure provides the safety-critical output of the Rosemount 3051 Pressure Transmitter. The Rosemount 3051 safety-certified pressure transmitter is certified to:

- Low and high demand: Type B element
- Route 2H, Low Demand application: SIL 2 for random integrity at HFT=0, SIL 3 for random integrity at HFT=1
- Route 2H, High Demand application: SIL 2 and SIL3 for random integrity at HFT=1
- Route 1H where the SFF $\geq 90\%$: SIL 2 for random integrity at HFT=0, SIL 3 for random integrity at HFT=1
- SIL 3 for systematic integrity

7.1 Identify Rosemount 3051 safety certification

You must identify all Rosemount 3051 transmitters as safety-certified before installing into SIS systems. To identify a safety-certified Rosemount 3051:

Procedure

1. Check NAMUR Software Revision located on the metal device tag: SW_ . _ . _ .
NAMUR Software Revision Number: SW⁽³⁾ 1.0.x-1.4.x
2. Verify that option code QT is included and TR is not included in the transmitter model code.
Devices used in safety applications with ambient temperatures below -40 °F (-40 °C) require option codes QT and BR5 or BR6.

7.2 Installation in SIS applications

Only qualified personnel should install the Rosemount 3051 Transmitter in SIS applications. There are no special installation instructions in addition to the standard installation practices outlined in this document.

Always ensure a proper seal by installing the electronics housing cover(s) so that metal contacts metal.

See the *Specifications* section of the Rosemount 3051 [Product Data Sheet](#) for environmental and operational limits.

Design the loop so that terminal voltage does not drop below 10.5 Vdc when the transmitter output is set to 23 mA.

(3) NAMUR Software Revision: Located on the metal device tag.

Position the security switch to the Lock position to prevent accidental or deliberate change of configuration data during normal operation.

7.3 Configuring in SIS applications

Use any HART® capable configuration tool to communicate with and verify configuration of the Rosemount™ 3051.

Note

Transmitter output is not safety-rated during the following: configuration changes, multidrop, and loop test. Use alternative means to ensure process safety during transmitter configuration and maintenance activities.

7.3.1 Damping

User-selected damping affects the transmitter's ability to respond to changes in the applied process. The damping value + response time must not exceed the loop requirements.

Reference [Damping](#) to change damping value.

7.3.2 Alarm and saturation levels

Configure DCS or safety logic solver to match transmitter configuration.

The figures below identify the three alarm levels available and their operation values.

Figure 7-1: Rosemount Alarm Level

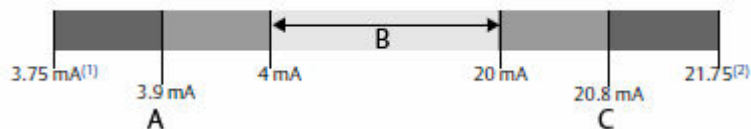

- A. Low saturation
- B. Normal operation
- C. High saturation

Figure 7-2: NAMUR Alarm Level

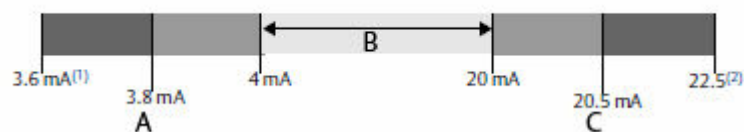

- A. Low saturation
- B. Normal operation
- C. High saturation

Figure 7-3: Custom Alarm Level

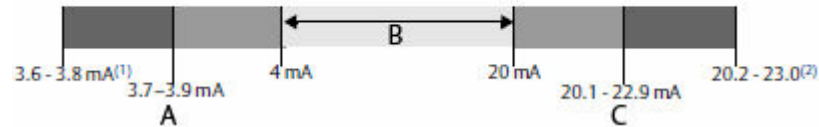

- A. Low saturation
- B. Normal operation
- C. High saturation

1. Transmitter failure, hardware or software alarm in LO position.
2. Transmitter failure, hardware or software alarm in HI position.

7.4 SIS operation and maintenance

7.4.1 Proof test

Emerson recommends the following proof tests.

In the event that an error is found in the safety and functionality, proof test results and corrective actions taken can be documented at [Emerson.com/ReportFailure](https://www.emerson.com/ReportFailure).

All proof test procedures must be carried out by qualified personnel.

Use [Field Communicator menu trees and fast keys](#) to perform a loop test, analog output trim, or sensor trim. Verify the Security switch is in the **Unlock** position during the proof test and reposition it in the **Lock** position after the proof test.

7.4.2 Partial proof test

The simple suggested proof test consists of a power cycle plus reasonability checks of the transmitter output. Reference the *FMEDA Report* for possible DU failures in the device.

See [Emerson.com/Rosemount](https://www.emerson.com/Rosemount) for the *FMEDA Report*.

Prerequisites

Required tools:

- Field Communicator
- mA meter

Procedure

1. Bypass the safety function and take appropriate action to avoid a false trip.
2. Use HART[®] Communication to retrieve any diagnostics and take appropriate action.
3. Select a HART command to the transmitter to the high alarm current output and verify that the analog current reaches that value.⁽⁴⁾

See [Verifying alarm level](#).

4. Send a HART command to the transmitter to go to the low alarm current output and verify that the analog current reaches that value.⁽⁴⁾
5. Remove the bypass and otherwise restore the normal operation.
6. Place the **Security** switch in the Lock position.

7.4.3 Comprehensive proof test

The comprehensive proof test consists of performing the same steps as the simple suggested proof test but with a two point calibration of the pressure sensor in place of the reasonability check. Reference the *FMEDA Report* for percent of possible DU failures in the device.

Prerequisites

Required tools:

- Field Communicator
- Pressure calibration equipment

Procedure

1. Bypass the safety function and take appropriate action to avoid a false trip.
2. Use HART[®] communication to retrieve any diagnostics and take appropriate action.
3. Send a HART command to the transmitter to go to the high alarm current output and verify that the analog current reaches that value.⁽⁴⁾
See [Verifying alarm level](#).
4. Send a HART command to the transmitter to go to the low alarm current output and verify that the analog current reaches that value.⁽⁵⁾
5. Perform a two-point calibration of the sensor over the full working range and verify the current output at each point.
See [Trim the pressure signal](#).
6. Remove the bypass and otherwise restore the normal operation.
7. Place the **Security** switch in the Lock position.

Note

- You determine the proof test requirements for impulse piping.
 - Automatic diagnostics are defined for the corrected % DU. The device performs these tests internally during runtime without requiring you to enable or program the transmitter.
-

⁽⁴⁾ This tests for possible quiescent current related failures.

⁽⁵⁾ This tests for compliance voltage problems, such as a low loop power supply voltage or increased wiring distance. This also tests for other possible failures.

7.4.4 Calculation of average probability of failure on demand (PFD_{AVG})

You can find PFD_{AVG} calculation in the *FMEDA Report* located at [Emerson.com/Rosemount](https://www.emerson.com/Rosemount).

7.5 Inspection

7.5.1 Product repair

You can repair the Rosemount 3051 by replacing major components.

Report all failures detected by the transmitter diagnostics or by the proof-test. Submit feedback electronically.

Only qualified personnel should repair the product and replace parts.

7.5.2 Rosemount 3051 SIS reference

Operate the Rosemount 3051 in accordance with the functional and performance specifications provided in the *Specifications* section of the Rosemount 3051 [Product Data Sheet](#).

7.5.3 Failure rate data

The *FMEDA Report* includes failure rates and common cause Beta factor estimates.

See the [FMEDA Report](#).

7.5.4 Failure values

Safety deviation: ±2.0 percent

Transmitter response time: Reference the *Specifications* section of the Rosemount 3051 [Product Data Sheet](#).

Self-diagnostics test interval: At least once every 60 minutes

7.5.5 Product life

50 years - based on worst case component wear-out mechanisms; not based on wear-out of process wetted materials.

A Reference data

A.1 Ordering information, specifications, and drawings

To view current Rosemount 3051 ordering information, specifications, and drawings, follow these steps:

Procedure

1. Go to [Emerson.com/Rosemount/Rosemount-3051](https://emerson.com/Rosemount/Rosemount-3051).
2. Scroll as needed to the green menu bar and click Documents & Drawings.
3. For installation drawings, click Drawings & Schematics and select the appropriate document.
4. For ordering information, specifications, and dimensional drawings, click Data Sheets & Bulletins and select the appropriate Product Data Sheet.

A.2 Product certifications

To view current Rosemount 3051 product certifications, follow these steps:

Procedure

1. Go to [Emerson.com/Rosemount/Rosemount-3051](https://emerson.com/Rosemount/Rosemount-3051).
2. Scroll as needed to the green menu bar and click Documents & Drawings.
3. Click Manuals & Guides.
4. Select the appropriate Quick Start Guide.

B Field Communicator menu trees and fast keys

B.1 Field Communicator menu trees

Figure B-1: Overview

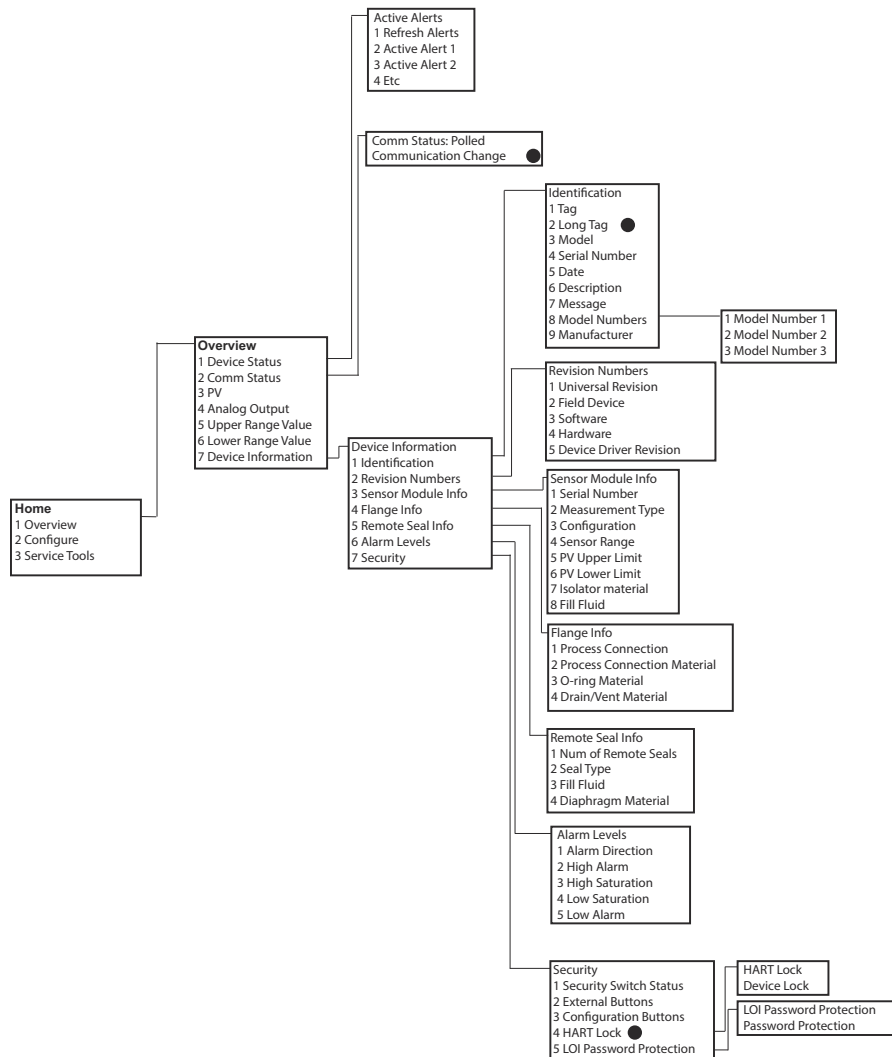

Selections with black circle are only available in HART® Revision 7 mode. Selection will not appear in HART Revision 5 DD.

Figure B-2: Configure - Guided Setup

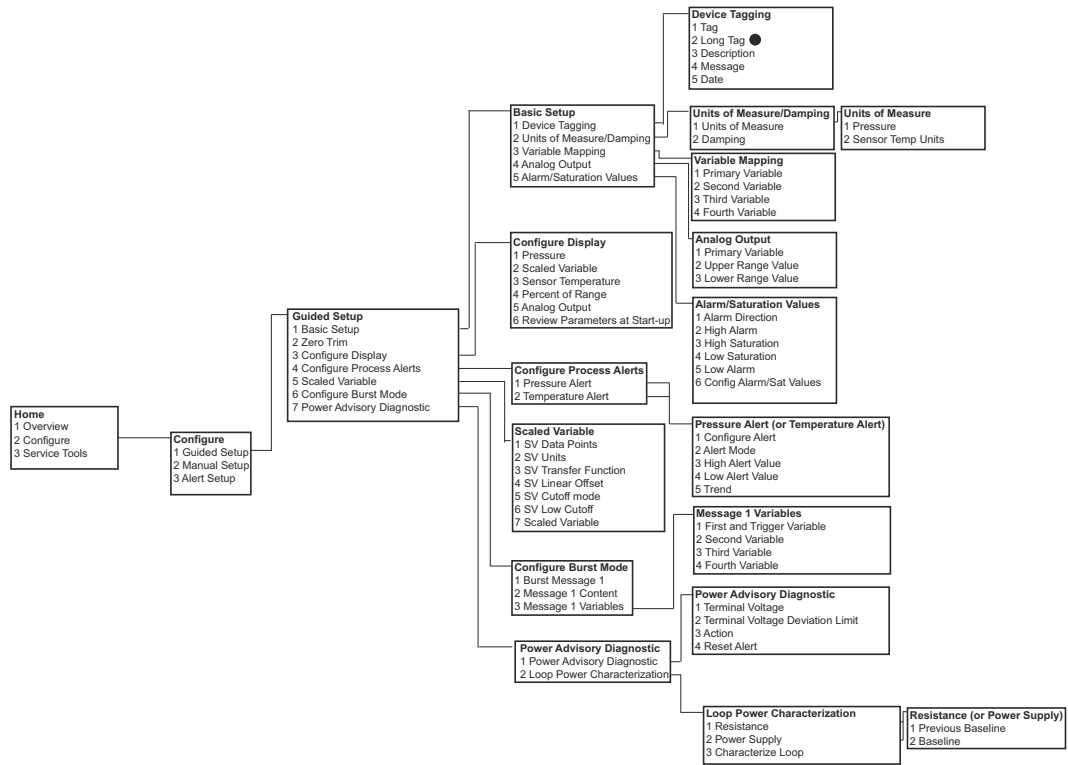

Selections with black circle are only available in HART Revision 7 mode. Selection will not appear in HART Revision 5 DD.

Figure B-3: Configure - Manual Setup

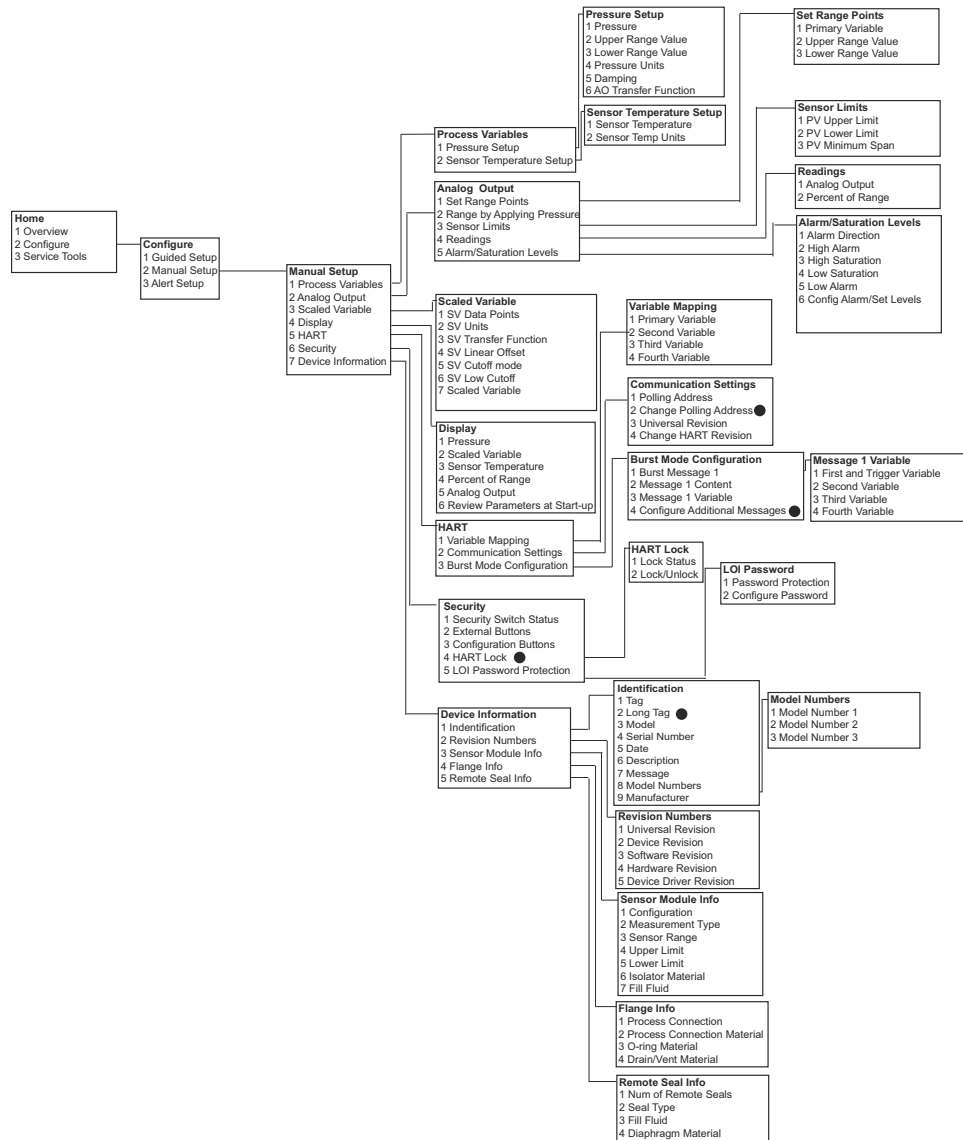

Selections with black circle are only available in HART Revision 7 mode. Selection will not appear in HART Revision 5 DD.

Figure B-4: Configure - Alert Setup

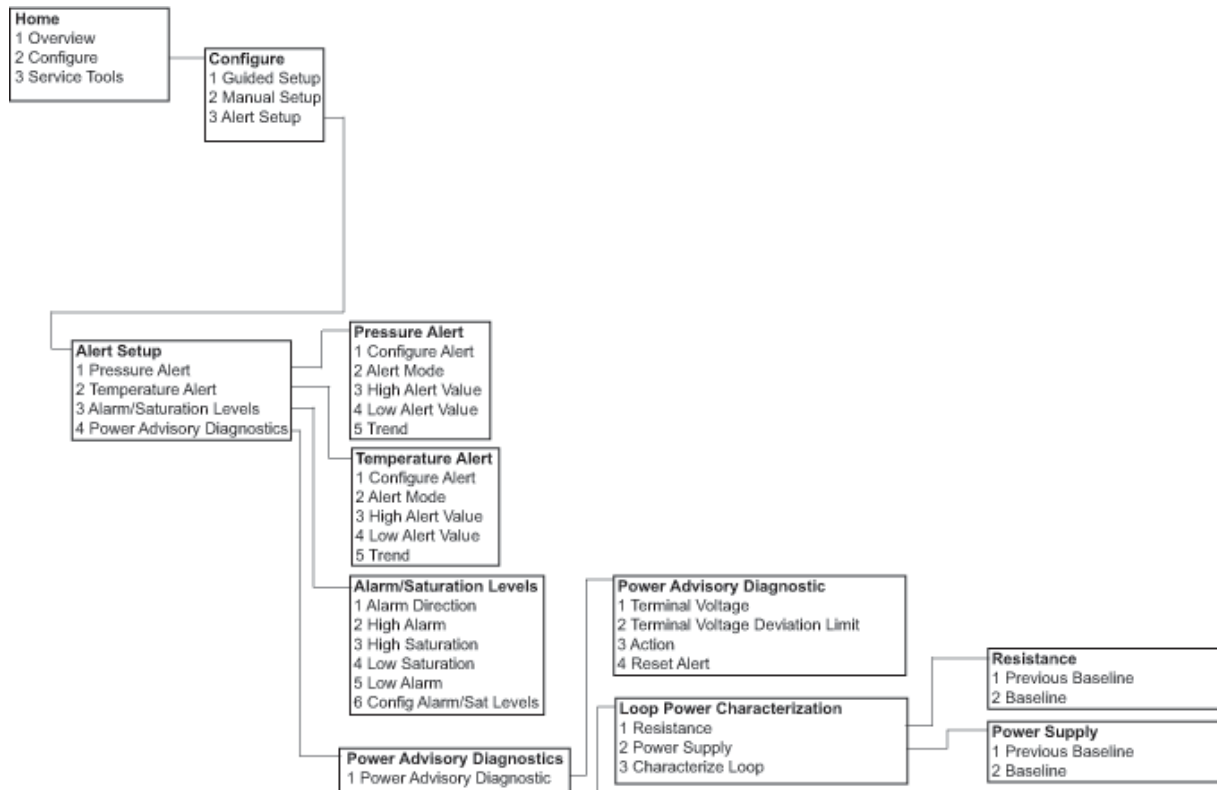

Selections with black circle are only available in HART Revision 7 mode. Selection will not appear in HART Revision 5 DD.

Figure B-5: Service Tools

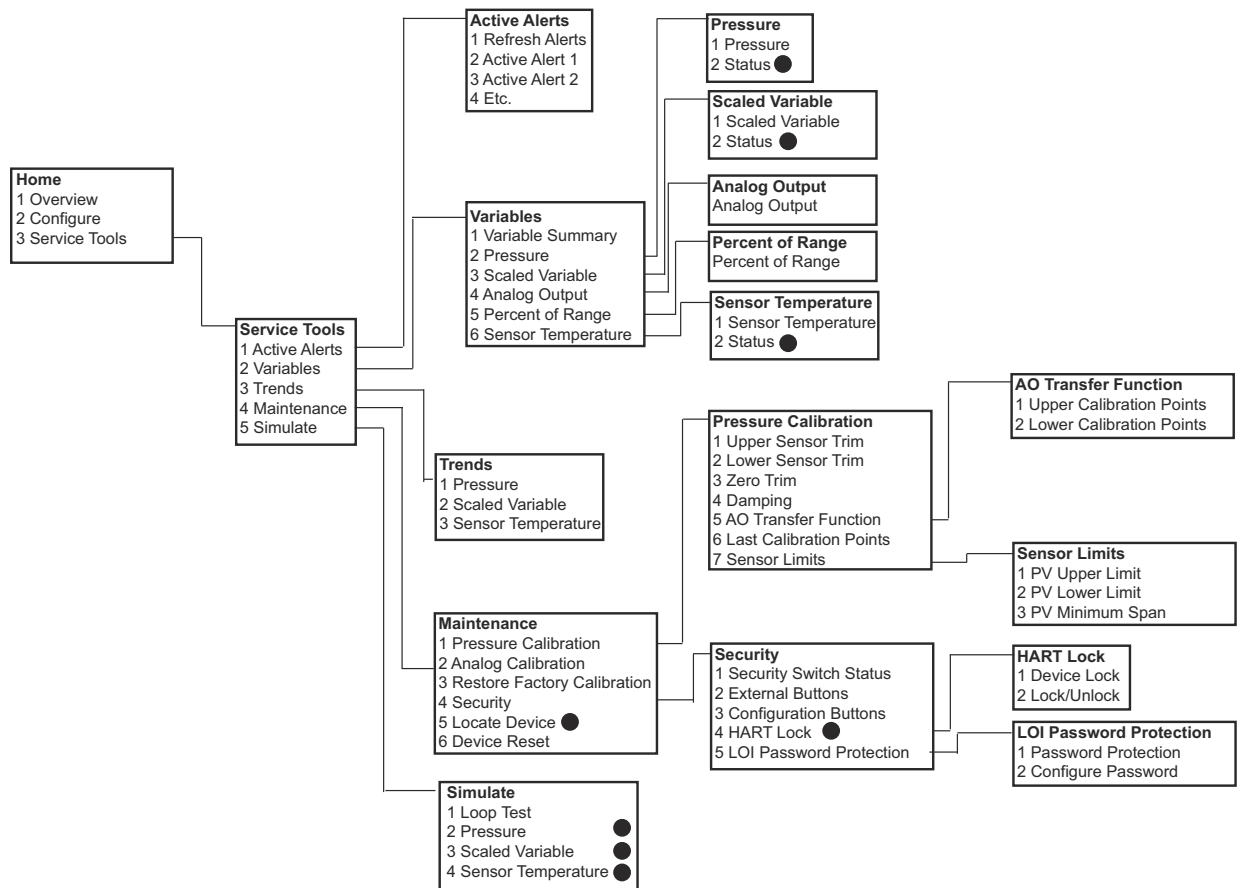

Selections with black circle are only available in HART Revision 7 mode. Selection will not appear in HART Revision 5 DD.

B.2 Field Communicator Fast Keys

- A (✓) indicates the basic configuration parameters. At minimum, verify these parameters as a part of configuration and startup.
- A (7) indicates availability only in HART® revision 7 mode.

Table B-1: Device Revision 9 and 10 (HART 7), DD Revision 1 Fast Key sequence

	Function	Fast Key sequence	
		HART 7	HART 5
✓	Alarm and Saturation Levels	2, 2, 2, 5	2, 2, 2, 5
✓	Damping	2, 2, 1, 1, 5	2, 2, 1, 1, 5
✓	Primary Variable	2, 2, 5, 1, 1	2, 2, 5, 1, 1
✓	Range Values	2, 2, 2, 1	2, 2, 2, 1

Table B-1: Device Revision 9 and 10 (HART 7), DD Revision 1 Fast Key sequence (continued)

	Function	Fast Key sequence	
		HART 7	HART 5
✓	Tag	2, 2, 7, 1, 1	2, 2, 7, 1, 1
✓	Transfer Function	2, 2, 1, 1, 6	2, 2, 1, 1, 6
✓	Pressure Units	2, 2, 1, 1, 4	2, 2, 1, 1, 4
	Date	2, 2, 7, 1, 5	2, 2, 7, 1, 4
	Descriptor	2, 2, 7, 1, 6	2, 2, 7, 1, 5
	Digital to Analog Trim (4 - 20 mA Output)	3, 4, 2, 1	3, 4, 2, 1
	Digital Zero Trim	3, 4, 1, 3	3, 4, 1, 3
	Display Configuration	2, 2, 4	2, 2, 4
	LOI Password Protection	2, 2, 6, 5	2, 2, 6, 4
	Loop Test	3, 5, 1	3, 5, 1
	Lower Sensor Trim	3, 4, 1, 2	3, 4, 1, 2
	Message	2, 2, 7, 1, 7	2, 2, 7, 1, 6
	Pressure Trend	3, 3, 1	3, 3, 1
	Rerange with Keypad	2, 2, 2, 1	2, 2, 2, 1
	Scaled D/A Trim (4–20 mA Output)	3, 4, 2, 2	3, 4, 2, 2
	Scaled Variable	2, 2, 3	2, 2, 3
	Sensor Temperature Trend	3, 3, 3	3, 3, 3
	Switch HART Revision	2, 2, 5, 2, 4	2, 2, 5, 2, 3
	Upper Sensor Trim	3, 4, 1, 1	3, 4, 1, 1
7	Long Tag	2, 2, 7, 1, 2	
7	Locate Device	3, 4, 5	
7	Simulate Digital Signal	3, 5	

C Local Operator Interface (LOI)

C.1 LOI menu tree

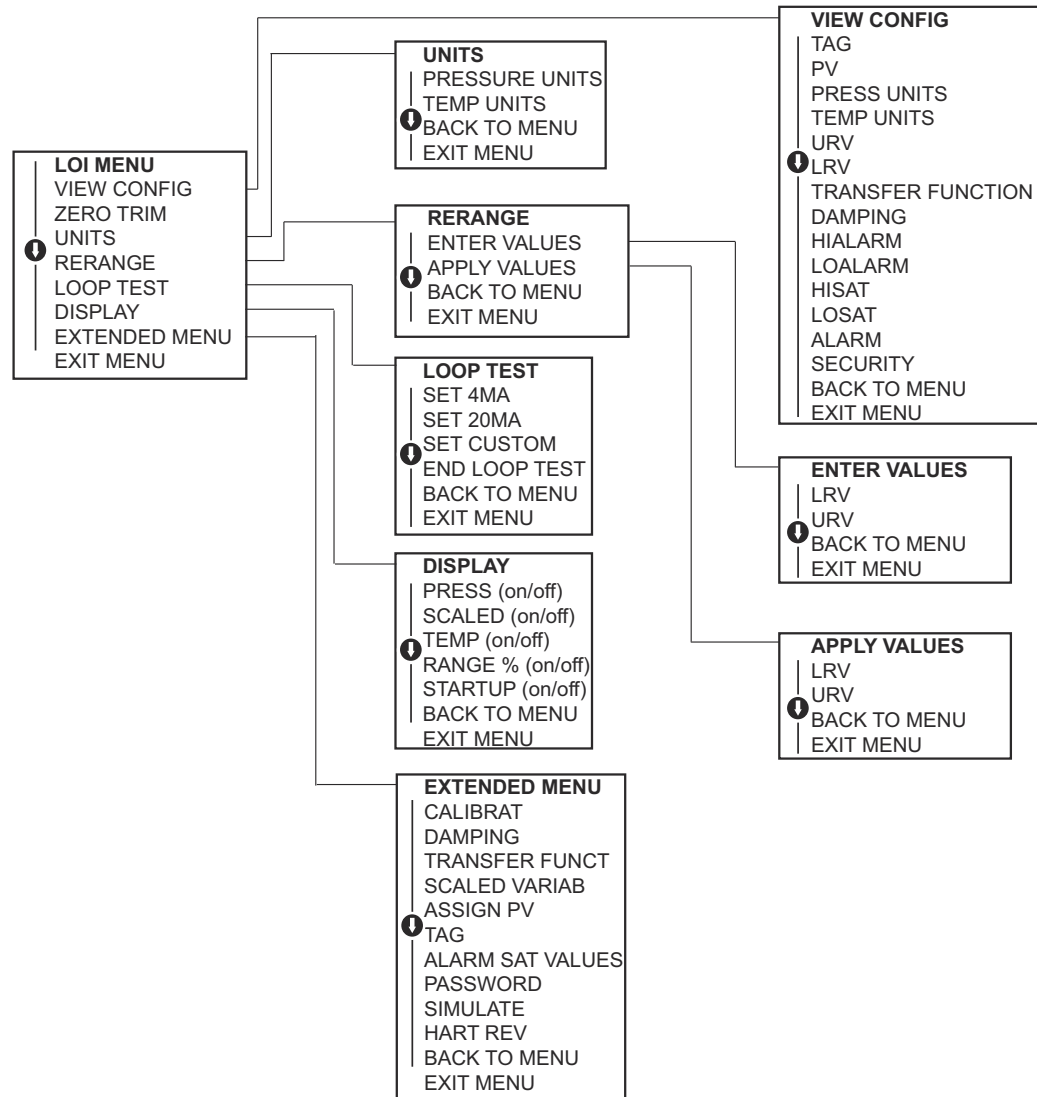

C.2 LOI menu tree - extended menu

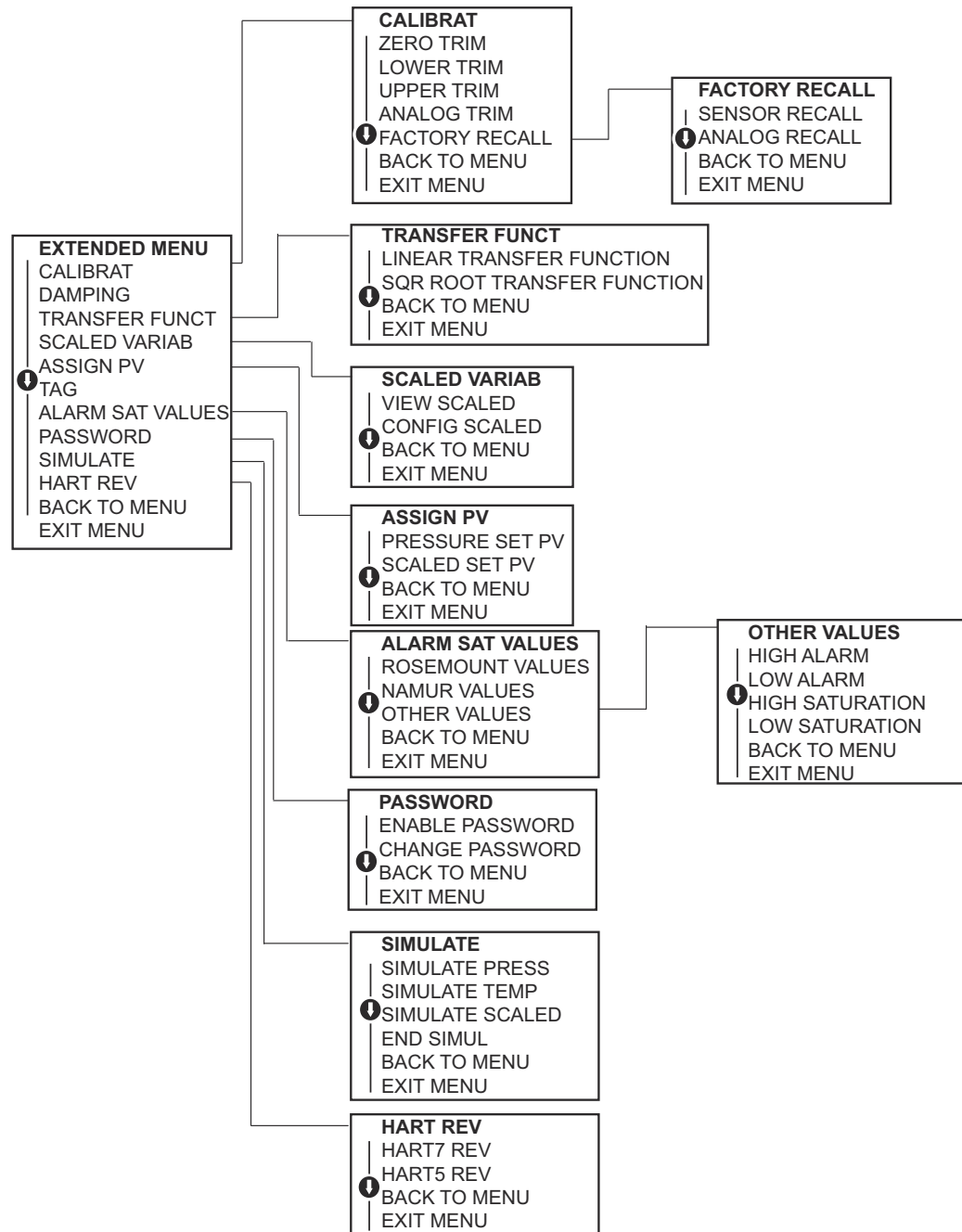

C.3 Enter numbers in the LOI

You can enter floating-point numbers with the LOI using all eight number locations on the top line.

Refer to [Table 2-2](#) for LOI button operation. The steps below give an example of how to change a value of -000022 to 00011.2.

When the number entry begins, the leftmost position is the selected position. In this example, the negative symbol "-" is flashing on the screen: `_000022`

Procedure

1. Press the **Scroll** button until the 0 is blinking on the screen in the selected position.
`0000022`
2. Press the **Enter** button to select 0 as an entry.
The second digit from the left is blinking: `0000022`
3. Press the **Enter** button to select 0 for the second digit.
The third digit from the left is blinking: `0000022`
4. Press the **Enter** button to select 0 for the third digit.
The fourth digit from the left is blinking: `0000022`
5. Press the **Enter** button to select 0 for the fourth digit.
The fifth digit from the left is blinking: `0000022`
6. Press the **Scroll** button to navigate through the numbers until 1 is on the screen.
`0000122`
7. Press the **Enter** button to select 1 for the fifth digit.
The sixth digit from the left is blinking: `0000122`
8. Press the **Scroll** button to navigate through the numbers until 1 is on the screen.
`0000122`
9. Press the **Enter** button to select 1 for the sixth digit.
The seventh digit from the left is blinking: `0000122`
10. Press the **Scroll** button to navigate through the numbers until the decimal "." is on the screen.
`00001.2`
11. Press the **Enter** button to select the decimal "." for the seventh digit.
After you press Enter, all digits to the right of the decimal become 0. The eighth digit from the left is blinking: `00001.0`
12. Press the **Scroll** button to navigate through the numbers until 2 is on the screen.
`00001.2`
13. Press the **Enter** button to select 2 for the eighth digit.
`00001.2`

The number entry is complete. A **SAVE** screen appears.

Usage notes

- To move backwards in the number, scroll to the Left arrow symbol and press **Enter**.
- The negative symbol is only allowed in the leftmost position.

- To enter numbers in scientific notation, place an E in the seventh position.

C.4 Enter text in the LOI

You can enter text in the LOI.

Depending on the edited item, you can enter text in up to eight locations on the top line. Text entry follows the same rules as the number entry rules in [Enter numbers in the LOI](#), except the following characters are available in all locations: A-Z, 0-9, -, /, space.

Note

If the current text contains a character the LOI cannot display, it will be shown as an asterisk "*".

Emerson Automation Solutions

6021 Innovation Blvd.
Shakopee, MN 55379, USA
📞 +1 800 999 9307 or +1 952 906 8888
📠 +1 952 204 8889
✉️ RFQ.RMD-RCC@Emerson.com

North America Regional Office

Emerson Automation Solutions
8200 Market Blvd.
Chanhassen, MN 55317, USA
📞 +1 800 999 9307 or +1 952 906 8888
📠 +1 952 204 8889
✉️ RMT-NA.RCCRFQ@Emerson.com

Latin America Regional Office

Emerson Automation Solutions
1300 Concord Terrace, Suite 400
Sunrise, FL 33323, USA
📞 +1 954 846 5030
📠 +1 954 846 5121
✉️ RFQ.RMD-RCC@Emerson.com

Europe Regional Office

Emerson Automation Solutions Europe
GmbH
Neuhofstrasse 19a P.O. Box 1046
CH 6340 Baar
Switzerland
📞 +41 (0) 41 768 6111
📠 +41 (0) 41 768 6300
✉️ RFQ.RMD-RCC@Emerson.com

Asia Pacific Regional Office

Emerson Automation Solutions
1 Pandan Crescent
Singapore 128461
📞 +65 6777 8211
📠 +65 6777 0947
✉️ Enquiries@AP.Emerson.com

Middle East and Africa Regional Office

Emerson Automation Solutions
Emerson FZE P.O. Box 17033
Jebel Ali Free Zone - South 2
Dubai, United Arab Emirates
📞 +971 4 8118100
📠 +971 4 8865465
✉️ RFQ.RMTMEA@Emerson.com

 [Linkedin.com/company/Emerson-Automation-Solutions](https://www.linkedin.com/company/Emerson-Automation-Solutions)

 [Twitter.com/Rosemount_News](https://twitter.com/Rosemount_News)

 [Facebook.com/Rosemount](https://www.facebook.com/Rosemount)

 [Youtube.com/user/RosemountMeasurement](https://www.youtube.com/user/RosemountMeasurement)

©2020 Emerson. All rights reserved.

Emerson Terms and Conditions of Sale are available upon request. The Emerson logo is a trademark and service mark of Emerson Electric Co. Rosemount is a mark of one of the Emerson family of companies. All other marks are the property of their respective owners.